

ED50/100/ED250

Swing Door Operators
Fine Cover and Narrow Header

Setup and Troubleshooting Instructions

DL4617-002 – 09-2021

| EN |

Table of contents

Table of contents	2	9	Parameters	16
1 General information	3	9.1	Parameters	16
1.1 General information	3	10	System setup for single door installation	18
2 Safety information	4	10.1	Set operator spring tension	18
3 Technical data	5	10.2	Set braking circuit plug position	19
3.1 ED50/ED100/ED250 technical data	5	10.3	Power on	20
3.2 Operating specifications – ED50 operator	6	10.4	Set installation type parameter AS	21
3.3 Operating specifications – ED100 and ED250 operators	6	10.5	Set door width parameter Tb	22
3.4 Torque overview – ED100 and ED250	7	10.6	Set reveal depth parameter rd	24
4 Operational mode overview	8	10.7	Set door type parameter dL	26
4.1 ED50/ED100/ED250 automatic and manual modes	8	10.8	Perform learning cycle	27
4.2 Low and full energy doors	8	10.9	Set power fail closing speed	28
5 User interface	10	11	Initial setup – pair doors	29
5.1 Overview	10	11.1	Separately setup active and inactive doors	29
5.2 4 button keypad and display	10	11.2	Set operator parameters for pair door operation	29
5.3 Mode switch and Exit Only switch panels	11	11.3	Connect sync cable between operators	30
6 System accessories	12	12	Set track bumper stop	31
6.1 System accessory electrical connection	12	12.1	Set track bumper stop position	31
6.2 System accessories	12	13	Install push arm door stop	32
6.3 Terminal board interfaces	13	13.1	Install push arm door stop (optional assembly)	32
7 ED50/ED100/ED250 door signage	14	14	Check door signage	33
7.1 ED100/ED250 configured for full energy	14	14.1	Check door signage	33
7.2 ED50 and ED100/ED250 configured for low energy	14	15	Install cover, end caps and spindle caps	33
8 Safety information labels	15	15.1	Install fine cover and end caps	33
8.1 Safety label, automatic swing doors	15	15.2	Install spindle caps, fine cover	34
8.2 Safety label, low energy swing doors	15	15.3	Install narrow header cover	34
		16	Upgrade cards	35
		16.1	Upgrade cards, ED50/ED100/ED250	35
		16.2	Container module	35
		16.3	Installing upgrade cards	36
		17	ANSI/BHMA standards	37
		17.1	A156.10 Power operated pedestrian doors	37
		17.2	A156.19 Low energy power operated doors	38
			Appendix A - Driving parameters	40
		A.1	Driving parameters – detail	40
			Appendix B - Troubleshooting	50
		B.1	Information and error codes	50
		B.2	Red LED status codes	51
		B.3	Troubleshooting chart, "In" codes	52
		B.4	Troubleshooting chart, "E" codes	53
			Appendix C - dormakaba handheld	56
		C.1	dormakaba handheld terminal	56
		C.2	New dormakaba handheld; language change to English	57
		C.3	dormakaba handheld; firmware update	58

1 General information

1.1 General information

1.1.1 Setup and Troubleshooting Instructions.

This manual provides Setup and Troubleshooting Instructions for ED50/ED100/ED250 fine cover and narrow header installations.

1.1.2 ED50/ED100/ED250 fine cover and narrow header installations.

NOTICE

Installation on an interior building surface.

The ED50/ED100/ED250 fine cover and ED50/ED100/ED250 narrow header must be installed on an interior building surface.

1.1.3 Exterior door use.

NOTICE

Exterior door use.

To insure proper suitability for exterior door use, the following topics must be addressed in the context of the door application setting.

- Site-specific use factors such as high wind conditions and/or building pressure.
- Door width, height, weight, and usage patterns.
- Observable prevailing conditions at the opening under which the operator is expected to perform. In some instances, this may require increased force settings to counteract these conditions.
- Door mounted presence sensors. When attempting to overcome these forces, it is strongly suggested that door mounted presence sensors be employed to enhance pedestrian safety through the opening.

1.1.4 Manual storage.

This document must be kept in a secure place, and accessible for reference as required.

If the door system should be transferred to another facility, insure that this document is transferred as well.

1.1.5 dormakaba.us website.

Manuals are available for review, download, and printing on the dormakaba.us website.

1.1.6 Dimensions

Unless otherwise specified, all dimensions are given in both inches (") and [mm].

1.1.7 Symbols used in these instructions.



WARNING

This symbol warns of hazards which could result in personal injury or threat to health.

CAUTION

This symbol warns of a potentially unsafe procedure or situation.

NOTICE

Draws attention to important information presented in this document.



TIPS AND RECOMMENDATIONS

Clarifies instructions or other information presented in this document.

2 Safety information

2.1 Safety instructions.

This document contains important instructions for setup and troubleshooting instructions for ED50/ED100/ED250 swing door operators used in fine cover and narrow header installations. Review these instructions thoroughly prior to setup, and follow them carefully during installation, setup, troubleshooting and maintenance.

2.2 Door signage requirements.

Proper signs and labels shall be applied and maintained on the door controlled by an ED50/ED100/ED250 swing door operator. Reference:

- ED50/ED100/ED250 Fine Cover Installation Instructions DL4616-004.
- ED50/ED100/ED250 Narrow Header Installation Instructions DL4616-005.

2.3 Safety warnings.



WARNING

An incorrect installation may result in damage to equipment or incorrect equipment operation.



WARNING

Hazard to mechanical processes by use of control settings, elements, or procedures not documented in this manual!



WARNING

Electric shock hazard!
By use of control elements, settings, or procedures not documented in this manual!



WARNING

Work on electrical equipment and 115 Vac wiring installation must be only be performed by qualified personnel!



WARNING

Metallic doors must be grounded per national and local codes!



WARNING

Hand pinch point and crushing hazards at door closing edges!



WARNING

Crushing hazards at door closing edges!

Fig. 2.1 Door closing edges

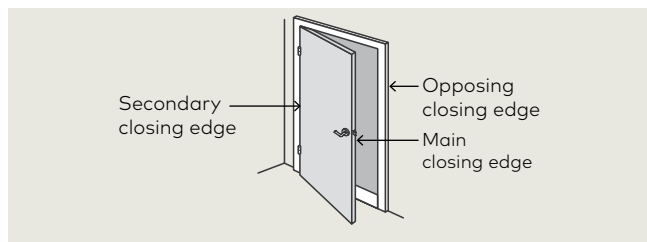

2.4 Residual hazards.



WARNING

After installation, hazards such as minor crushing, impact with limited force, and risk to unsupervised children may exist depending on structural design of door area, type of door, and any safeguards that have been implemented.



WARNING

Hand pinch point and crushing hazards at arm and track!

Fig. 2.2 Push arm

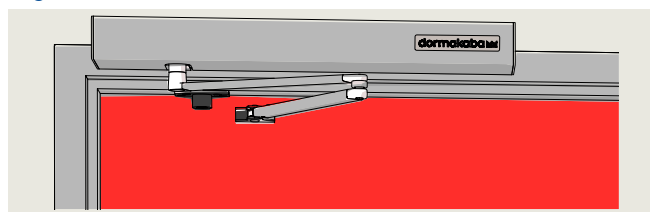
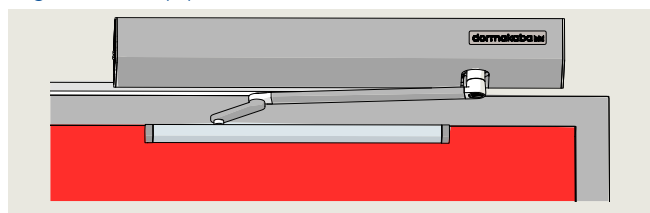

Fig. 2.3 Deep pull arm



3 Technical data

3.1 ED50/ED100/ED250 technical data

3.1.1 Required operating conditions.

Ambient temperature	5 to 122 °F [-15 to 50° C]
Suitable for dry rooms only	Relative air humidity: 93% maximum, non-condensing
Power supply	115 Vac ±10%, 50/60 Hz 6.6 A maximum
Branch circuit protection (provided by others)	15 A maximum, dedicated branch circuit
Protection class	NEMA 1 [IP20]
Power wiring: black, white, bare copper (ground)	12 AWG maximum
Operating noise	Maximum 50 db(A)

3.1.2 General specifications.

Operator dimensions (W x H x D)	27" x 2 3/4 x 5 1/8" [685 x 70 x 130 mm] 27" cover standard
Operator weight	21.8 lb [9.9 kg]
ED100/ED250: Power supply for accessories	24 Vdc ± 5%, 1.5 A.
ED50: Power supply for accessories	External power supply is required.
Maximum door opening angle	95 to 110° depending on installation type

3.1.3 Inputs

Wire size Connector plug screw size	14 AWG 1/16"
Activation inputs X4*	Interior, exterior N. O. contact
Safety sensors X5	Swing, approach sides.
Night-bank (intercom system) X10 57, 57a	8-24 Vdc/Vac +5%
Night-bank (key switch) X1 35, 3	d2 parameter Configure for N.O. or N.C. contact
Deactivation of drive function X6 4, 4a	d1 parameter Configure for N.O. or N.C. contact

***X4**: terminal board numbers, reference Chapter 6, Terminal board connections.

3.1.4 Outputs

Maximum wire size Connector plug screw size	16 AWG 1/16"
Door status X7 97,98,99	Sr parameter Door closed Door open Door closed, locked Com, N.O., N.C. contacts

3.1.5 Integrated functions.

Hold open time Automatic opening	dd parameter	0 to 30 s Optional 0 - 180 s.
Hold open time Night bank	dn parameter	0 to 30 s
Hold open time Manual opening	do parameter	0 to 30 s
Door blocking behavior	hd parameter	Automatic, manual door modes
Electric strike delayed opening for locking mechanism	Ud parameter	0 to 4 s
Locking device feedback X3 43, 3	Chapter 6	Motor lock
Wind load control, maximum	Fo, Fc parameters	33.7 lb f 150 N
Voltage independent braking circuit	Chapter 10	Adjustable with potentiometer
LED status indicators Green, Red, Yellow		24 Vdc power Error codes Service interval
Mode and Exit Only switches	Chapter 4	Auto, Close, Open Exit only; Off, On
User interface		4 button keypad, 2 digit display
Slot for upgrade cards	Chapter 16	Extension of functional range.
Firmware update		Firmware update
TMP, temperature management program	Overload protection	
IDC, initial drive control	Driving phase optimization	
Cycle counter	CC parameter	0 to 1,000,000
Power assist function	hA, hF, hS parameters	Drive support for manual opening of door
Push & go function	PG parameter	Auto opening of door at 4° open

Fine cover, Narrow header

Setup and Troubleshooting Instructions

3.2 Operating specifications – ED50 operator

3.2.1 ED50		
Maximum power consumption	120 watts	
Opening force lbf - N Fo parameter	Minimum 4.5 [20]	Maximum 13.5 [60]
Manual closing force lbf - N Fc parameter	Minimum 4.5 [20]	Maximum 13.5 [60]
Maximum door weight, lb [kg]	220 [100 kg]	Depending on door width and application.
Door width	Minimum 28"	Maximum 48"

Maximum opening speed, %s	27	May be limited by door weight after learning cycle.
Maximum closing speed, %s	27	
Axle extensions	13/16" [20 mm] 2 3/8" [60 mm]	
Reveal depth for pull arm with CPD lever	0 to 2 1/4" [0 to 57.1 mm]	
Reveal depth for standard push arm	0 to 11 13/16" [0 to 300 mm]	

3.3 Operating specifications – ED100 and ED250 operators

3.3.1 ED100	
Maximum power input	120 watt
Closing torque	
Maximum door weight	FE: 250 lb [113kg], depending on specific door application. LE: 600 lb [272kg], depending on specific door application.
Door width	28" - 55" [700 - 1400 mm]
Opening speed 0 - 90°	4* - 12 seconds
Closing speed 90 - 0°	5* - 21 seconds
Axle extensions	20/30/60 mm
Reveal depth, slide channel (CPD)	0 to 2 1/4" [0 to 57/1 mm]
Reveal depth, standard push arm	0 - 11 13/16" [0 - 300 mm]
Reveal depth, deep push arm	0 - 19 11/16" [0 - 500 mm]

3.3.2 ED250	
Maximum power input	240 watt
Closing torque	
Maximum door weight.	FE: 320 lb [145 kg] depending on specific door application. LE: 700 lb [318 kg] depending on specific door application.
Door width	28" - 63" [700 - 1600 mm]
Door width fire protection	28" - 55" [700 - 1400 mm]
Opening speed 0 - 90°	3* - 12 seconds
Closing speed 90 - 0°	4* - 21 seconds
Axle extensions	20/30/60/90 mm
Reveal depth, slide channel (CPD)	0 to 2 1/4" [0 to 57/1 mm]
Reveal depth, standard push arm	0 - 11 13/16" [0 - 300 mm]
Reveal depth, deep push arm	0 - 19 11/16" [0 - 500 mm]

*Depending on door panel weight, automatically limited with low energy power operator doors (ANSI A156.19).

Maximum speeds will only be reached in full energy operating mode, low door panel weight, and a minimum learned opening angle of 95°.

Fine cover, Narrow header

Setup and Troubleshooting Instructions

3.4 Torque overview – ED100 and ED250

	Mounting on hinge side, pull version of slide channel.			Mounting on opposite hinge side, push version of standard arm/ push version of slide channel		
3.4.1 ED100	Minimum	Maximum		Minimum	Maximum	
Closer size in accordance with EN1154	EN 2	EN 4		EN 2	EN 4	
Manual closing torque: ft lb [Nm]***	9.6 [13]	27.3 [37]		9.6 [13]	27.3 [37]	
Automatic closing force lb f [N]**	4.5 [20]	FE 34 [150]	LE 15 [67]	4.5 [20]	FE 34 [150]	LE 15 [67]
Manual opening torque: ft lb [Nm]	22 [30]	37 [50]		26 [35]	40.6 [55]	
Automatic opening force lb f [N]**	4.5 [20]	FE 34 [150]	LE 15 [67]	4.5 [20]	FE 34 [150]	LE 15 [67]
Opening force of manually activated power-assist function lb f [N]*	5.2 [23]	5.2 [23]		5.2 [23]	5.2 [23]	
3.4.2 ED250	Minimum	Maximum		Minimum	Maximum	
Closer size in accordance with EN1154	EN 4	EN 6		EN 4	EN 6	
Manual closing torque: ft lb [Nm]***	19 [26]	48 [65]		19 [26]	66 [90]	
Automatic closing force lb f [N]**	4.5 [20]	FE 34 [150]	LE 15 [67]	4.5 [20]	FE 34 [150]	LE 15 [67]
Manual opening torque: ft lb [Nm]	40.6 [55]	63 [85]		44 [60]	66 [90]	
Automatic opening force lb f [N]**	4.5 [20]	FE 34 [150]	LE 15 [67]	4.5 [20]	FE 34 [150]	LE 15 [67]
Opening force of manually activated power-assist function lb f [N]*	5.2 [23]	5.2 [23]		5.2 [23]	5.2 [23]	

FE – Configured for full energy

LE – Low energy basic device, or configured for low energy

*If power assist support set to maximum, effective from an opening width of approximately 3°.

** The torque is available in the event of an automatic opening in automatic mode.

*** In the push version of the slide channel installation type, the forces reduce by approximately 33%.

4 Operational mode overview

4.1 ED50/ED100/ED250 automatic and manual modes

4.1.1 Automatic mode.

Manual/automatic mode parameter **hd**=0.
Setting if door is opened automatically following pulse generation by an activation or knowing act device.

4.1.2 Manual mode.

Manual/automatic mode parameter **hd**=1.
Setting if door is opened manually most of the time and only rarely automatically.

4.1.3 Power assist.

- Available only in manual mode (**hd**=1). Drive support is automatically adjusted to operator size.
- Parameter **hA** sets door activation angle for power assist function. Once angle reached, drive support provides easier manual opening of the door.
- Parameter **hF**, power assist function. Parameter decreases the amount of force required to open the door.
- Parameter **hS**, power assist function support for door in closed position.



TIPS AND RECOMMENDATIONS

Parameter descriptions can be found in Chapter 11; Parameters.

4.2 Low and full energy doors

4.2.1 Low energy power operated door (ANSI/BHMA A156.19).

1. ED50 is available only as a low energy operator.
2. ED100 and ED250 operator default is low energy. **F2** parameter = 0.

4.2.1.1 Low energy power operated door definition.

A door with a power mechanism that opens the door upon receipt of a **knowing act** activating signal, does not generate more kinetic energy than specified in ANSI 156.19, and is closed by a power mechanism or by other means.

Required system safety, as a low energy application, is achieved utilizing the following design factors:

- Reduced dynamic door panel contact forces.
- Reduced static door panel contact forces.
- Low driving speeds.
- Force limitation.

4.2.1.2 Knowing act definition.

Any conscious action with the expected result of opening a door. This includes but is not limited to:

- Wall or jamb mounted contact or non contact switches such as pushplates.
- The action of manually opening (pushing or pulling) a door.
- Controlled access devices such as keypads, card readers, wireless transmitters and key switches.

4.2.2 Power operated door (ANSI/BHMA A156.10).

ED100 and ED250 operators can be configured for full energy (power operated door).

F2 parameter = 2.

4.2.2.1 Power operated door definition.

The combination of door, operator, controls and sensors constituting the system (Also called automatic door).

This page left intentionally blank.

5 User interface

5.1 Overview

- 1 2 digit display
- 2 4 button keypad

Fig. 5.1.1 Operator keypad and display

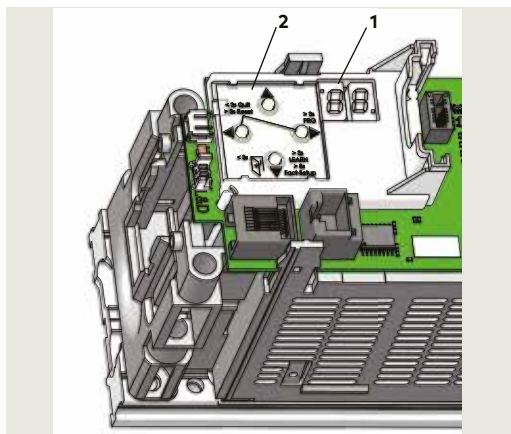

5.1.1 Operator user interfaces.

1. 4 button keypad and 2 digit display.
- 4 button keypad; to select, input and adjust door parameter values.
- 2 digit display; parameter values, error and information codes.

5.2 4 button keypad and display

- 2 2 digit display
- 5 Button legend

Fig. 5.2.1 Door hinge side on right

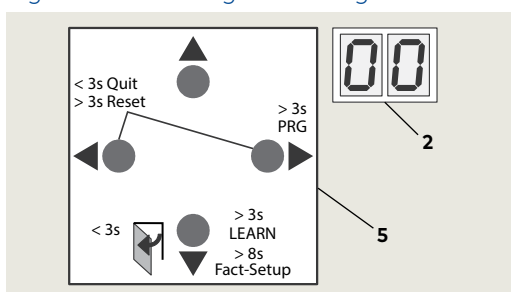

5.2.1 4 button keypad.

4 button legend is orientated so buttons have same function and position regardless of operator orientation. Button legend can be removed and rotated.

5.2.2 4 button keypad functions.

▶	Right button	<ol style="list-style-type: none"> 1. Access parameter menu, press button > 3 seconds. 2. Edit selected parameter. 3. Save changed value.
◀	Left button	<ol style="list-style-type: none"> 1. Reset, > 3s 2. Quit process, < 3 s.
◀▶	Both buttons together	<ol style="list-style-type: none"> 1. Acknowledge errors, press both buttons < 3 s. 2. Reset, press both buttons > 3 s.
▲	Up button	<ol style="list-style-type: none"> 1. Scroll through parameters and error messages. 2. Increase parameter value.
▼	Down button	<ol style="list-style-type: none"> 1. Scroll through parameters and error messages. 2. Reduce parameter value. 3. Opening pulse, press button < 3 s. 4. Learning cycle, press button > 3 s. 5. Reset with factory setting, press button > 8 s (program switch Close position). 6. Identify operator orientation for display

- 2 2 digit display
- 6 Button legend rotated 180°

Fig. 5.2.2 Door hinge side on left

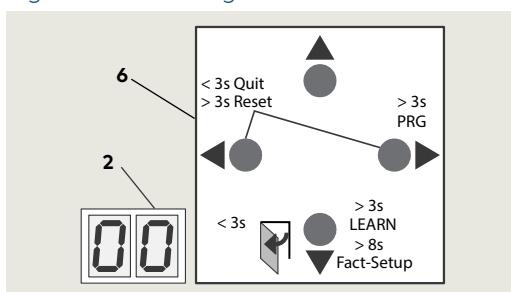

TIPS AND RECOMMENDATIONS

Symbols

- "<", Less than
- ">", Greater than

Fine cover, Narrow header

Setup and Troubleshooting Instructions

5.3 Mode switch and Exit Only switch panels

Fig. 5.3.1 Fine cover

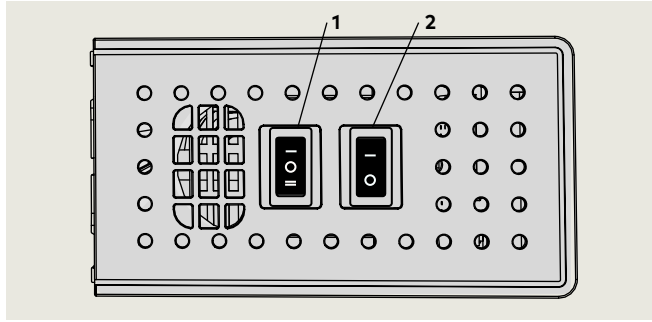

- 1 Mode switch, 3 position
- 2 Exit Only switch, 2 position

Fig. 5.3.8 Narrow header

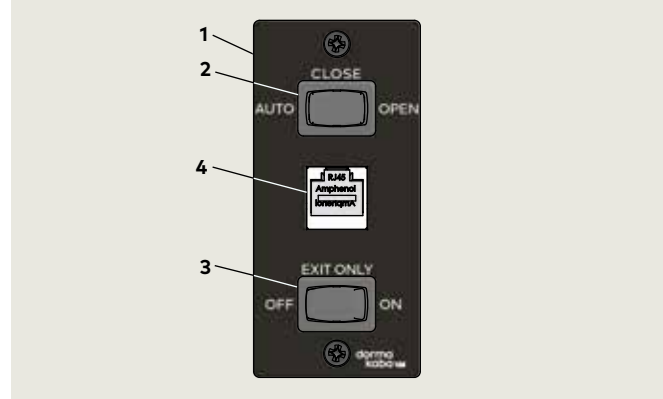

- 1 Mode switch panel
- 2 Mode switch, three position
- 3 Exit Only switch, two position
- 4 RJ45 Comm port for service

Fig. 5.3.2 Optional key switch panels



5.3.1 Mode switch positions.

Fig. 5.3.3 Auto

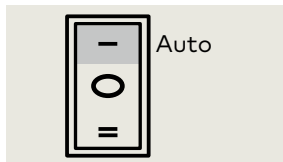

Fig. 5.3.4 Close

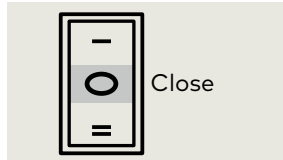
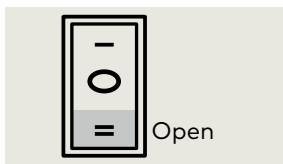

Fig. 5.3.5 Open



5.3.2 Exit Only switch positions.

Fig. 5.3.6 On

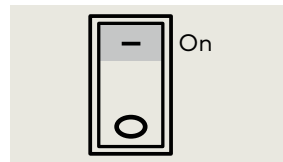
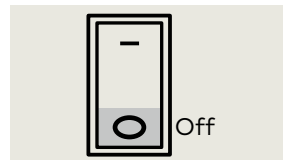

Fig. 5.3.7 Off



5.3.3 Mode switch position descriptions.

Auto

1. Door opens automatically when one of the activators is actuated or triggered. Door closes on expiration of adjustable hold open time with no activators or actuators triggered.
2. With knowing act device actuation (Para. 4.2.3). Door will remain at full open position for not less than 5 seconds.
3. With push/pull actuation of door (Para. 7.2). Door will remain at full open position for not less than 3 seconds.

Close

1. Door will remain closed, or if door is open door will close.

Open

1. Door opens automatically and remains open.

5.3.4 Exit Only switch position descriptions.

On

1. Exterior activation sensor or knowing act device disabled when door fully closed.
 - Only interior activation sensor or knowing act device will enable door opening.

Off

1. Both interior and exterior activation sensors or knowing act devices will enable door opening.

6 System accessories

6.1 System accessory electrical connection

Fig. 6.1.1 Electrical connections, single door

- 1 External mode switch, mechanical
- 2 External mode switch, electronic
- 3 Key switch
- 4 Pushbutton, night / bank
- 5 Pushbutton, interior
- 6 Pushbutton, exterior
- 7 Door locking device
- 8 Manual release switch
- 9 ED50/ED100/ED250

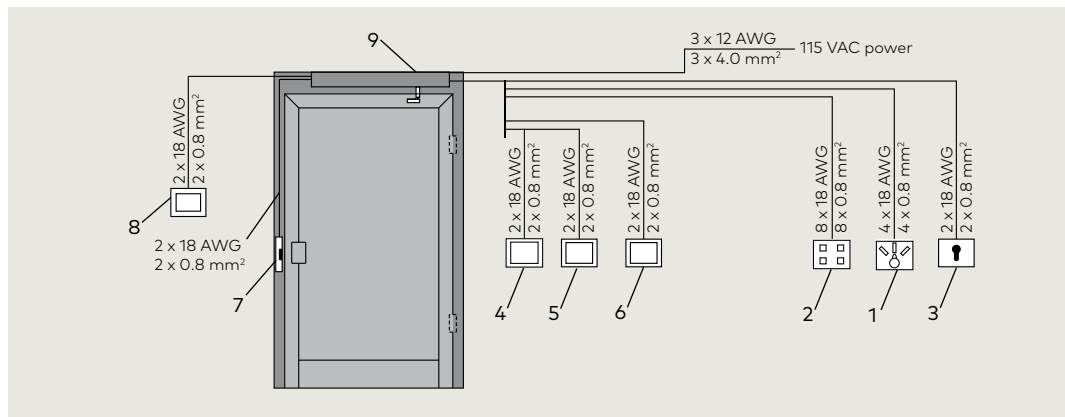

6.2 System accessories

6.2.1 Overview

ED50/ED100/ED250 operators are normally used with system accessories available from dormakaba USA, Inc. or other manufacturers.

6.2.2 Accessory electrical installation.

Electrical interfaces from system accessories used with operator must be planned for. This includes routing of wiring from accessories to operator.

6.2.3 System accessories, other manufacturers.

dormakaba USA cannot guarantee compatibility for other manufacturer's accessories. If any of these accessories are used despite this caution, the operator's full range of functions may be unavailable, or the accessories may not function properly.



WARNING

Damage to operator or to connected device is also possible!

6.2.4 ED100/ED250 power for accessories.

1. 24 Vdc, 1.5 A (36 watts) is available from the operator for external consumers. This supply has overcurrent protection. If additional power is required, an external power supply must be used.

6.2.5 ED50 power for accessories.

1. An external supply is required for accessories.

6.2.6 Door status display.

1. Door status display: red, yellow, green.
 - Reference: Appendix B, Troubleshooting.

6.2.7 Activators

Typical activators:

1. Pushbuttons, key switches
2. Access control systems
3. Telephone systems
4. Intercoms
5. Sensor automatic activators (ANSI/BHMA A156.10).



TIPS AND RECOMMENDATIONS

Refer to Chapter 3, Technical data for electrical interface requirements.

6.2.8 Locking devices.

Typical locking devices:

1. Electric strike plates
2. Electromagnetic locks
3. Electric locks

To insure that operator and locking device work safely when connected together, locking device must comply with following:

1. Operating voltage, power supply from operator, 24 Vdc, $\pm 5\%$.
2. Operating voltage, external power supply, 48 Vdc/ Vac maximum.
3. Locking device relay contact, maximum load, 1 A.
4. Electric strike plate duty factor, 30% minimum.
5. Motor lock duty factor, 100%.

Fine cover, Narrow header

Setup and Troubleshooting Instructions

6.3 Terminal board interfaces

Fig. 6.11 ED50/ED100/ED250 terminal board electrical connections

- 1 Green LED (Para. 4.4)
- 2 Yellow LED (Para. 4.4)
- 3 Red LED (Para. 4.4)
- 4 Key (red insert) location in socket. Assigned plug has tab in same location broken off.
- 5 Jumpers, factory installed at following terminals:
 - 4 and 4a
 - 15 and 3*
 - 11 and 3*
- 6 DCW upgrade card plug
- 7 Fire protection upgrade card plug

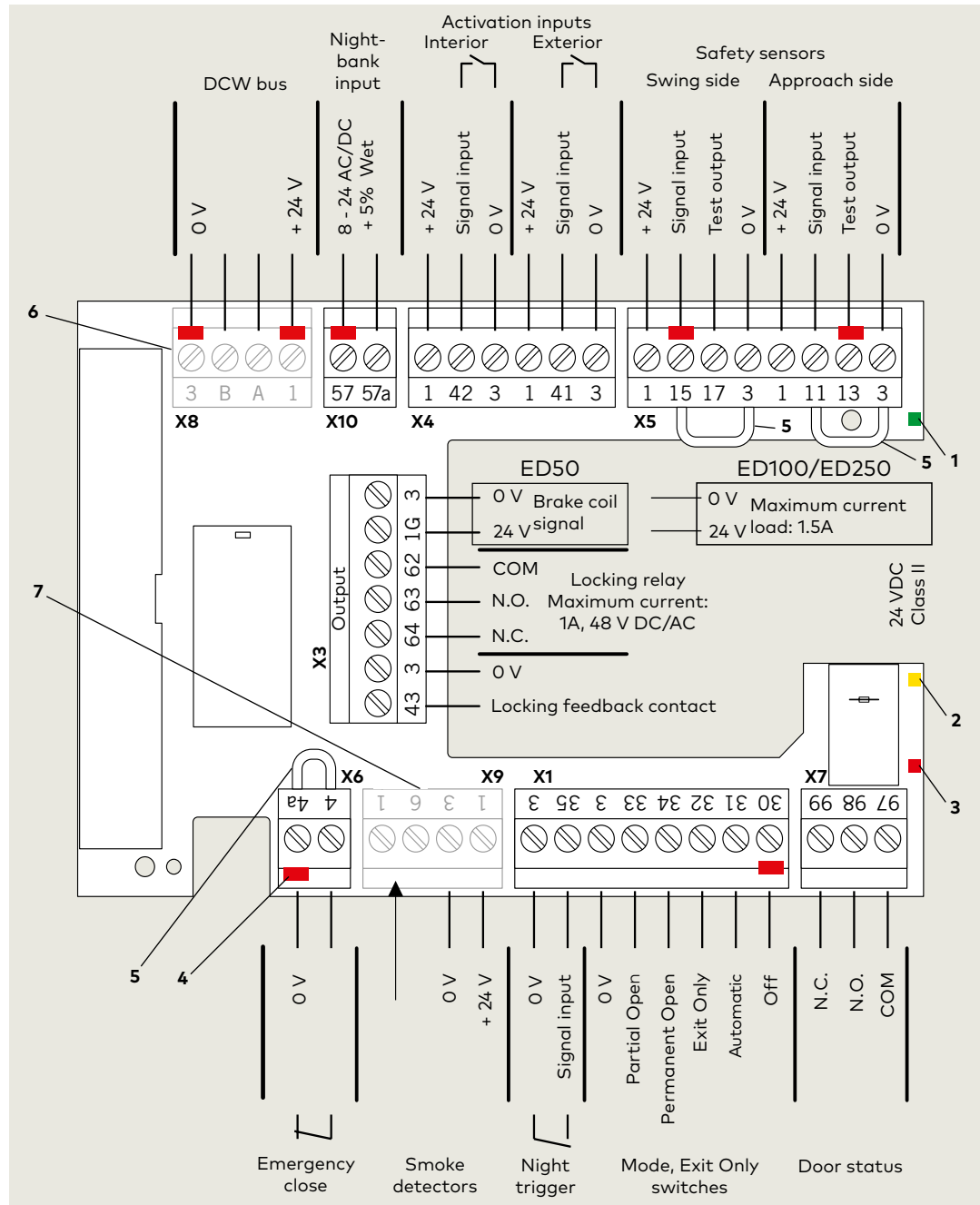

TIPS AND RECOMMENDATIONS

- Use documentation provided with each device for electrical installation.
- It is recommended not to connect system accessories to board until after operator has been setup and learning cycle performed (Chapter 10).

Note 1: Terminals 3 and 43 are also used for swing side overhead sensor input when parameter ST is set to 7 or 8. Reference Appendix A, Parameters.

7 ED50/ED100/ED250 door signage

7.1 ED100/ED250 configured for full energy

7.1.1 Overview

Signage and warnings are specified in ANSI /BHMA A156.10, American National Standard for Power Operated Pedestrian Doors, paragraph 11.

7.1.2 Door, one way traffic, Fig. 7.1.1.

1. Arrow and AUTOMATIC DOOR, one side of decal.
 - Shall be visible from approach side of a swinging door, mounted on door at a height of 50" ± 12" from floor to centerline of sign.
2. DO NOT ENTER and AUTOMATIC DOOR, one side of decal (or separate decal for solid doors - DD0739-020).
 - Shall be visible from non-approach side of door that swings towards pedestrians attempting to travel in wrong direction.

7.1.3 Door, two way traffic, Fig. 7.1.2.

1. Arrow and AUTOMATIC DOOR, one side of decal.
 - Shall be visible from approach side of a swinging door, mounted on door at a height of 50" ± 12" from floor to centerline of sign.
2. CAUTION AUTOMATIC DOOR, one side of decal.
 - Swinging doors serving both egress and ingress shall have a "CAUTION AUTOMATIC DOOR" sign visible from swing side of door.
 - Sign shall be mounted on door at a height of 50 ± 12" from floor to centerline of sign.

Fig. 7.1.1 One decal, approach side, non-approach side

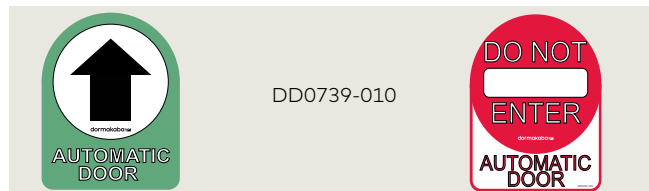

Fig. 7.1.2 One decal, two way traffic

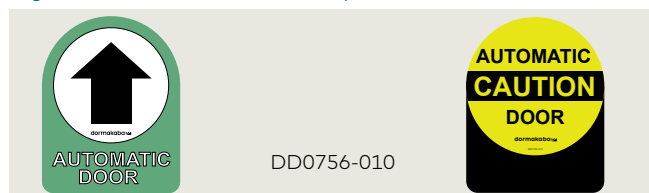

Fig. 7.1.3 ACTIVATE SWITCH TO OPERATE decal



7.1.4 Knowing act door.

1. ACTIVATE SWITCH TO OPERATE decal.
 - Knowing act doors shall have signage stating "ACTIVATE SWITCH TO OPERATE" on side of door having knowing act switch or other knowing act device.

7.2 ED50 and ED100/ED250 configured for low energy

7.2.1 Overview

Signage and warnings are specified in ANSI /BHMA A156.19, American National Standard for Power Assist and Low Energy Power Operated Doors.

7.2.2 All low energy doors.

1. AUTOMATIC CAUTION DOOR decal.
 - All low energy doors shall be marked with signage visible from both side of door with the words "AUTOMATIC CAUTION DOOR".
 - Signs shall be mounted 50" ± 12" from floor to centerline of sign.

7.2.3 Knowing act switch used to initiate door operation.

1. ACTIVATE SWITCH TO OPERATE decal.
 - When a knowing act device is used to initiate operation of door operator, door shall be provided with sign on each side of door where switch is operated with message "ACTIVATE SWITCH TO OPERATE".

7.2.4 Push/Pull used to initiate door operation.

1. PUSH TO OPERATE, PULL TO OPERATE decals.
 - When push/pull is used to initiate operation of door operator, doors shall be provided with the message "PUSH TO OPERATE" on push side of door and "PULL TO OPERATE" on pull side of door.

Fig. 7.2.1 AUTOMATIC CAUTION DOOR decal

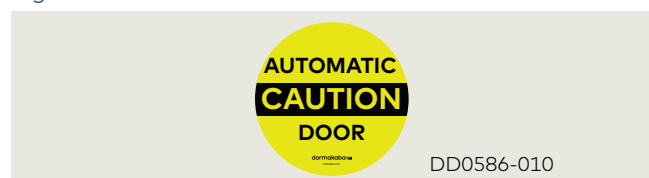
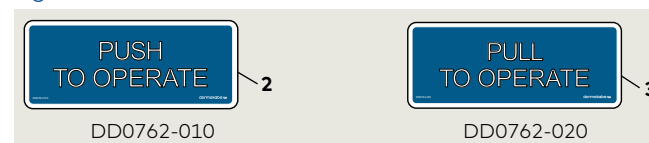

Fig. 7.2.2 ACTIVATE SWITCH TO OPERATE decal



- 1 Activate Switch to Operate DD0758-010

Fig. 7.2.3 PUSH TO OPERATE, PULL TO OPERATE decals



- 2 Push to Operate DD0762-010
- 3 Pull to Operate DD0762-020

8 Safety information labels

8.1 Safety label, automatic swing doors

8.1.1 Automatic swinging door safety information label

This AAADM label outlines safety checks that should be performed daily on automatic swinging door controlled by an ED100 or ED250 operator configured for full energy mode.

8.1.2 Safety information label location

Place label in a protected, visible location on door frame, near program switch panel if possible.

8.1.3 Annual compliance section of label

This section of label is only completed on automatic swing doors that comply with ANSI/BHMA A156.10 standard and pass inspection by an AAADM certified dormakaba USA, Inc. technician.

8.1.4 Additional annual compliance inspection labels

Place additional labels over annual compliance inspection section of safety information label.

8.2 Safety label, low energy swing doors

8.2.1 Low energy swinging door safety information label

This AAADM label outlines safety checks that should be performed daily on low energy swinging door controlled by an ED50 operator or an ED100/ED250 operator configured for the low energy mode.

8.2.2 Safety information label location

Place label in a protected, visible location on door frame, near program switch panel if possible.

8.2.3 Annual compliance section of label

This section of label is only completed on low energy swing doors that comply with ANSI/BHMA A156.19 standard and pass inspection by an AAADM certified dormakaba USA, Inc. technician.

8.2.4 Additional annual compliance inspection labels

Place additional labels over annual compliance inspection section of safety information label.

Fig. 8.1.1 Safety information labels

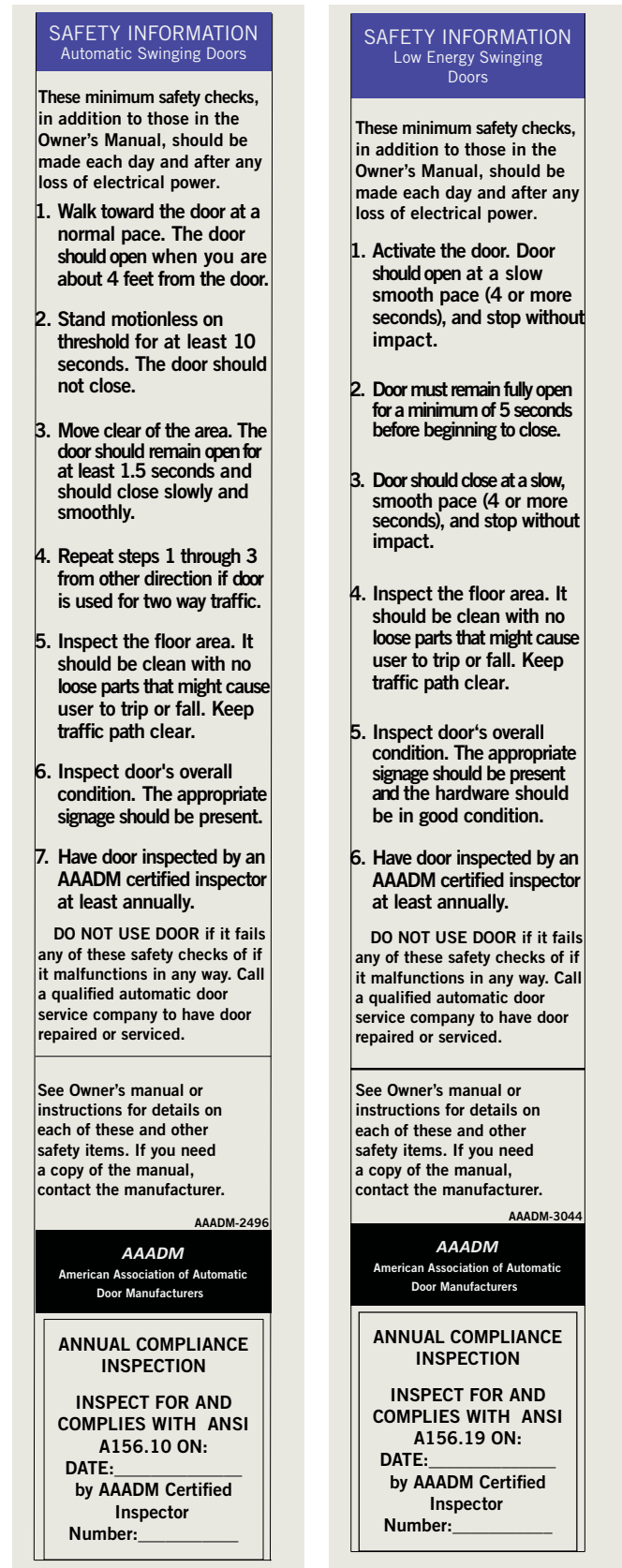
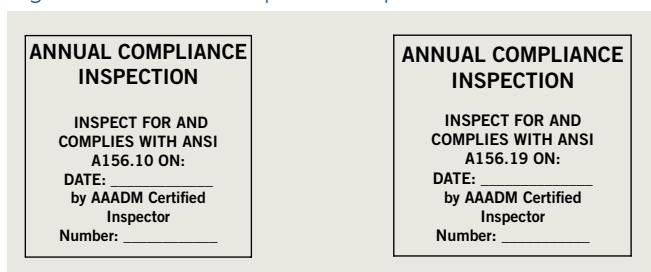

Fig. 8.1.2 Annual compliance inspection labels



9 Parameters

9.1 ED50/ED100/ED250 OHC – viewing and changing parameters

9.1.1 Changing parameter values.

1. Set Mode switch to the CLOSE position.

Fig. 9.1.1 Mode switch

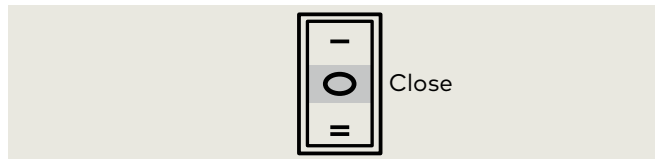

2.. Use 4 button keypad as outlined in Steps 1 through 8 to view or change parameter values.

Fig. 9.1.2 4 button keypad, 2 digit display

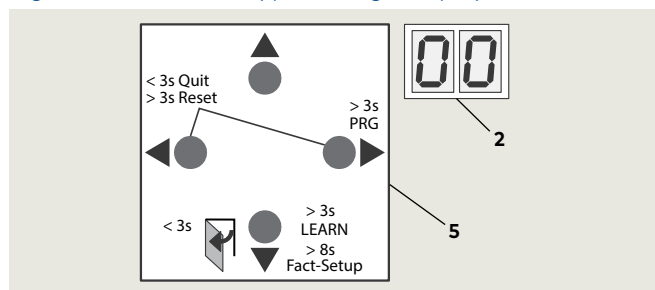

- 2 2 digit display
- 5 4 button keypad

Step 1 ▶	Press right button greater than 3 s to enter program mode.
Step 2 ◆	Press up or down button to scroll through parameters until desired parameter is displayed.
Step 3 ▶	Press right button to display current parameter value.
Step 4 ▶	Press right button again to enable editing of value, display will start flashing.
Step 4 ◆	Press up or down button to select desired parameter value.
Step 5 ▶	Press right button to save selected value. Display stops flashing.
Step 6 ◀	Press left button to return to selected parameter.
Step 7 ◆	Press up or down button to scroll through parameters until next desired parameter is displayed.
Step 8 ◀	Press left button for a minimum of 3 s to exit program mode.

9.2 Configuration parameters

9.2.1 Configuration parameters.

Configuration parameters (Table 9.2.1) are set during operator initial setup. Reference Chapter 10.

Table 9.2.1 Configuration parameters

Parameter	Description
1 AS AS	Installation type
2 rd rd	Reveal depth
3 Tb rb	Door width
4 dL dL	Door type

9.3 Driving parameters

9.3.1 Driving parameters.

























































Driving parameters (Table 9.3.1) can be set once initial setup (Chapter 10) has been completed.

- Reference Appendix A for driving parameter detail.

Fine cover, Narrow header

Setup and Troubleshooting Instructions









































Table 9.3.1 Driving parameters

Driving parameter	Description
5  	Opening speed, automatic mode
6  	Closing speed, automatic mode
7  	Hold open time, automatic mode
8  	Hold open time, night/bank
9  	Hold open time, manual opening of door
10  	Wall masking on door swing (hinge) side
11  	Safety sensor test
12  	Activation by safety sensor on approach (opposite hinge) side
13  	Suppression of safety sensor on swing (hinge) side during initial movement
14  	Locking mechanism delayed opening time
15  	Door preload prior to unlocking
16  	PR (Power reserve) module test
17  	Static force on door closing edge in opening direction (wind load control)
18  	Static force on door closing edge in closing direction (wind load control)
19  	Motor driven latching action, automatic mode
20  	Door opening angle at which motor driven latching action is activated
21  	Locking force
22  	Push and Go
23  	Mode (program) switch type
24  	DCW EPS, electronic program switch behavior following a power reset
25  	Internal Mode switch; switch function on delay
26  	Door unlocking during business hours
27  	Status relay function, terminal block X7
28  	Input 4/4a and X3, 1G 24V locking device output configuration
29  	Cycle counter, number displayed * 10000
30  	Delete error log
31  	Reset service interval display (yellow LED)
32  	Factory setting level (Fact Setup button)

NOTICE

Driving parameters - detail.

Reference Appendix A.

Driving parameter	Description
33  	Opening angle, set during learning cycle
34  	Door closer mode, automatic or manual
35  	Power assist function activation angle
36  	Power assist function force adjustment
37  	Power assist function support for manual mode in door closed position
38  	Upgrade card, fire protection
	ED50: F2 not used.
39  	F2=0 (default): Low energy: ANSI/BHMA A156.19 F2=2: Full energy: ANSI/BHMA A156.10
40  	Not used
41  	Not used
42  	Not used
43  	Upgrade card, barrier free toilet
44  	Upgrade card, DCW I/O module
45  	Configuration of COM 1 interface
46  	Back check angle when door opened manually
47  	Door thickness (mm)
48  	Deactivation of drive, emergency pushbutton at X4, 4 and 4a, trigger type
49  	Night/bank function, trigger type
50  	Hold open system release by manually closing door, trigger type
51  	Active door with astragal, caster angle; angle door must reach before passive door starts to open
52  	Hinge clearance

10 System setup for single door installation

10.1 Set operator spring tension

Fig. 10.1.1 Narrow header spring tension adjustment

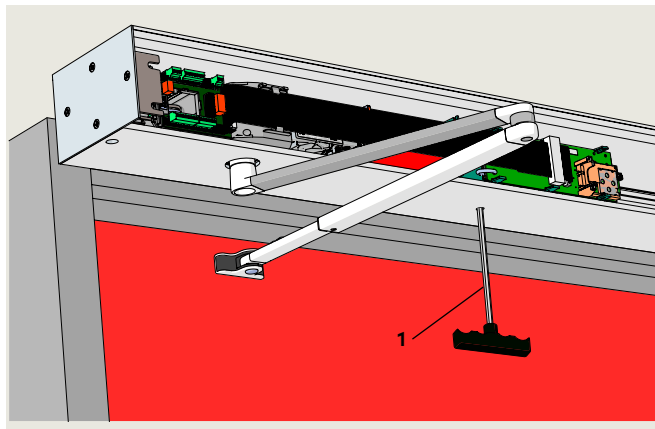

1 Spring tension adjustment

Fig. 10.1.2 Fine cover spring tension adjustment

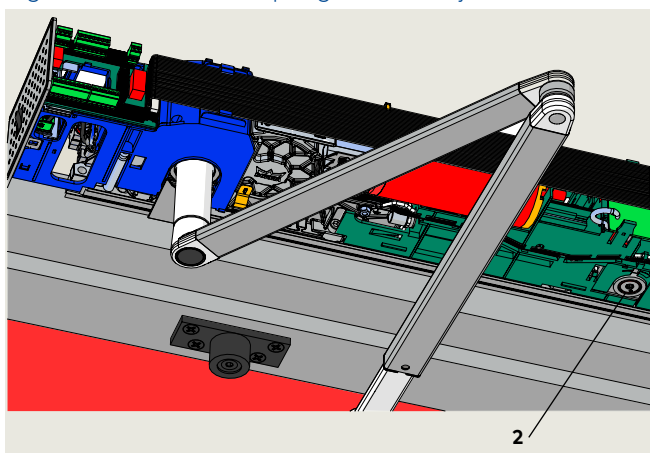

2 Spring tension adjustment

Fig. 10.1.3 5mm T-handle hexkey



Fig. 10.1.4 Door pressure gauge

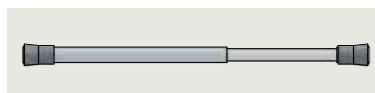

Table 10.1.1 Spring tension setting revolutions

Door width							
Inches	28	32	36	42	48	55	63
mm	711	813	914	1067	1219	1400	1600
Spring setting revolutions							
ED50/ ED100	10	10	14	16	18	---	---
ED250	10	10	14	16	18	24	24

10.1.1 Operator spring tension set during installation.

1. Check spring tension per Table 10.1.1.

10.1.2 Set spring tension.

1. Use 5 mm T-hand hex key to set Spring tension.
 Clockwise - increases spring tension.
 Counterclockwise - decreases spring tension.

CAUTION

A minimum of ten spring tension revolutions are required to operate system.

CAUTION

Any change to spring tension setting requires a new learning cycle!

10.1.4 Check door closing force.

1. Table 10.1.1 lists approximate spring tension settings.
2. Use pressure gauge to check door closing force at 2° and adjust tension setting if necessary.



TIPS AND RECOMMENDATIONS

Reference Chapter 17 for ANSI/BHMA standards for door closing forces.



TIPS AND RECOMMENDATIONS

System checks spring tension during learning cycle (Chapter 10).

Learning cycle will be canceled if spring is insufficiently tensioned; door will stop and display will show a rotating "0" and an "F".



Fine cover, Narrow header

Setup and Troubleshooting Instructions

10.2 Set braking circuit plug position

Fig. 10.2.1 Braking circuit socket and plug, plug factory installed in pull installation location

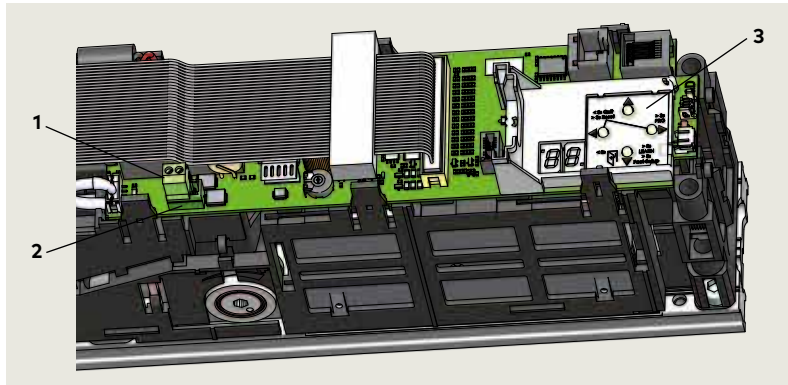

- 1 Braking circuit plug
- 2 Braking circuit
3 pin socket
- 3 User interface

Fig. 10.2.2 Plug position, pull installation

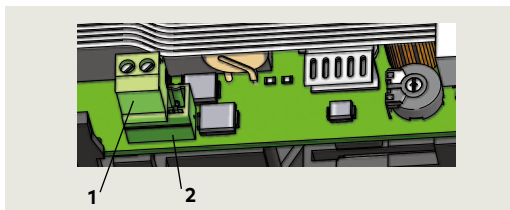

- 1 Braking circuit plug
- 2 Braking circuit
3 pin socket

Fig. 10.2.3 Power switch

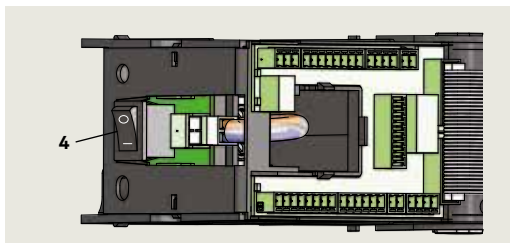

- 4 Power switch
(shown ON)

Fig. 10.2.4 Plug position, push installation

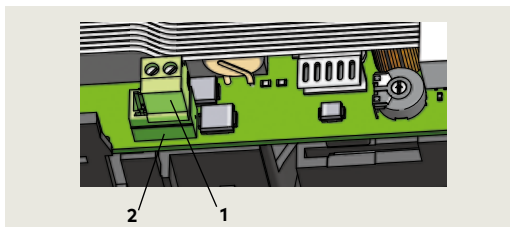

- 1 Braking circuit plug
- 2 Braking circuit
3 pin socket

10.2.1 Set braking circuit plug.

Operator braking circuit plug is positioned in its 3 pin socket for a push or pull installation.



WARNING

Braking circuit will not work correctly if braking circuit plug is improperly positioned, or if an incorrect plug is used!
Door may close at high speed and/or be difficult to open!

10.2.2 Factory-installed plug position.

Braking circuit plug is factory installed in the left two pins, the pull installation position (Fig. 10.2.1 and Fig. 10.2.2).

10.2.3 Change braking circuit plug position to push installation.

To change plug position for push installation, install plug in right two pins, toward user interface (Fig. 10.2.4).



WARNING

Insure power switch is OFF before changing plug position!

10.3 Power on

- 2 Power switch

Fig. 10.3.1 Power switch

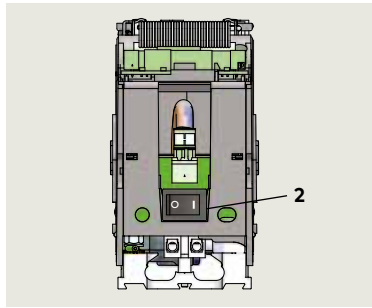

Fig. 10.3.2 Mode switch,

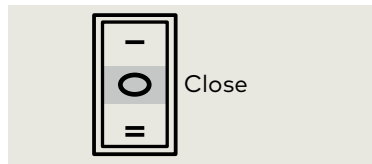
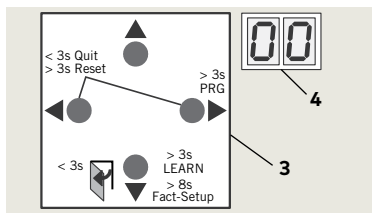

Fig. 10.3.3 4 button keypad, 2 digit display

- 3 Four button keypad
- 4 Two digit display



TIPS AND RECOMMENDATIONS

If pressing down button (Step 3) does not result in desired display orientation, return to Step 2, turn power button off, then on to repeat commissioning steps.

10.3.1 Conditions prior to Power On.

1. ED50/ED100/ED250 operator is installed.
2. Push arm or arm with track is installed.
3. Key switches and other separately supplied hardware are installed and connected to operator.
4. 115 Vac branch circuit to operator is energized.
5. Operator motor is cold.

CAUTION

Motor must be cold for commissioning!

10.3.2 Power On.

Step 1	Mode switch to CLOSE position.
Step 2	Power switch to ON position.
	System check. • Series of letters and numbers rapidly displayed.
	Control unit self check. • Two segments jumping back and forth.
	Horizontal dashes move up and down.
Step 3	Press 4 button keypad down button ▼.
	While 2 digit display segments move up and down, letters and numbers will change if required to display correct orientation.
	Display scrolls: • Device ID (Ed 100) as example. • Firmware version (format F x x x x)
	Program mode display. Program mode will be displayed indicating system requires further parameter settings.

Fine cover, Narrow header

Setup and Troubleshooting Instructions

10.4 Set installation type parameter AS

Table 10.4.1 AS parameter values

AS		Installation type.
Parameter value	Parameter description.	
0*	Pull <ul style="list-style-type: none"> Pull arm with CPD lever. Wall mounting on swing (hinge) side.	
1	Push <ul style="list-style-type: none"> Standard push arm. Deep push arm. Wall mounting on approach (non-hinge) side.	
2	Pull as push (ED100/ED250 only) <ul style="list-style-type: none"> Pull arm with CPD lever. Wall mounting on approach (non-hinge) side.	
5	ED250 only. Push ANSI size 6. Door width ≥ 55" [1400 mm]. Wall mounting on approach (non-hinge) side.	

AS factory setting = 0.

10.4.2 Set parameter AS value to 0.

Step 1 Press	Press PRG greater than 3 s to enter program mode, AS parameter displayed.
Step 2 Press	Displays "00", factory setting.
Step 3 Press	"00" starts flashing.
Step 4 Press	Scroll to "1".
Step 5 Press	Scroll to "0".
Step 6 Press	Saves "0" value for Pull. Display stops flashing.
Step 7 Press	Returns to Installation type parameter.
Step 7	Go to Para. 10.5, set door width parameter Tb.

10.4.1 Set AS parameter value.

NOTICE

- If pull installation is required, set AS = 0.
 - "0" is AS factory setting.
- For system to recognize AS = 0, steps in Para. 10.4.2 must be followed.
- Set AS parameter to value other than 0.
 - Follow steps in Para. 10.4.3

10.4.3 Set parameter AS to value other than 0.

Step 1 Press	Press PRG greater than 3 s to enter program mode, AS parameter displayed.
Step 2 Press	Displays "00", factory setting.
Step 3 Press	"00" starts flashing.
Step 4 Press	Scroll to "1" (push as example).
Step 5 Press	Saves "1" value for Push. Display stops flashing.
Step 6 Press	Returns to Installation type parameter.
Step 7	Go to Para. 10.5, set door width parameter Tb.

Fine cover, Narrow header

Setup and Troubleshooting Instructions

10.5 Set door width parameter Tb

10.5.1 Measure door width.

1. Measure door width in inches or mm

10.5.2 Set Tb door width parameter value.

NOTICE

1. If door width = 40 - 43 15/16", Set Tb = 10.
 - "10" is Tb factory setting.
 - For system to recognize Tb = 10, steps in Para. 10.5.3 must be followed.
2. Set TB parameter to value other than 10.
 - Follow steps in Para. 10.5.4

10.5.3 Set parameter TB value = 10.

Step 8 Press ▼		Scroll to Tb parameter.
Step 9 Press ▶		Displays "10", factory setting.
Step 10 Press ▶		"10" starts flashing.
Step 11 Press ◆		Scroll to 11
Step 12 Press ◆		Scroll to 10
Step 13 Press ▶		Saves value. Display stops flashing.
Step 13 Press ◀		Returns to door width parameter.
Step 14		Go to Para. 10.6, Set reveal depth rd.



10.5.4 Set parameter TB to value other than 10.

Step 8 Press ▼		Scroll to Tb parameter.
Step 9 Press ▶		Displays "10", factory setting.
Step 10 Press ▶		"10" starts flashing.
Step 11 Press ◆		Scroll to 11 (Door width = 44 - 47 15/16" as example)
Step 12 Press ▶		Saves value entered. Display stops flashing.
Step 13 Press ◀		Returns to door width parameter.
Step 14		Go to Para. 10.6, Set reveal depth parameter rd.

Fine cover, Narrow header

Setup and Troubleshooting Instructions

Table 10.5.1 Tb parameter values.

		Door width	
Door width measurement			
Inches	[mm]	Tb	
28 - 31 15/16	[711] - [811]	7	
32 - 35 15/16	[813] - [912]	8	
36 - 39 15/16	[914] - [1014]	9	
40 - 43 15/16	[1016] - [1116]	10*	
44 - 47 15/16	[1118] - [1218]	11	
48 - 51 15/16	[1219] - [1319]	12	

Tb factory setting = 10.

NOTICE

ED250 only.
Door widths 52" [1321 mm] and higher.
 Review the specific door application.
 Reference Para. 3.3, Operating specifications.

Table 10.5.2 Additional ED250 door widths.

Door width measurement		
Inches	[mm]	Tb
52 - 55 15/16	[1321] - [1421]	13
56 - 59 15/16	[1422] - [1522]	14
60 - 62 15/16	[1523] - [1599]	15
63	[1600]	16

Fine cover, Narrow header

Setup and Troubleshooting Instructions

10.6 Set reveal depth parameter rd

Fig. 10.6.1 Reveal depth parameter rd

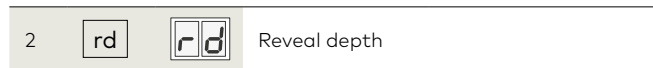

rd factory setting = 0.

10.6.1 Measure reveal depth.

1. Measure and record reveal depth.
 - Reveal depth is set in increments of 10 mm (approximately 3/8"). Reference Table 10.6.1.



TIPS AND RECOMMENDATIONS

- Use of pull arm with CPD lever.
 Value of parameter **rd** must be reduced by 3/16" [30].
- Example: ED100 installation with reveal of 30 mm (1 1/8").
 Parameter rd setting = 0
 (Reveal of 30 mm - 30 mm).

10.6.2 Set rd reveal depth parameter value.

NOTICE

1. If reveal depth = 0, set rd = 0.
 - "0" is rd factory setting.
 - For system to recognize rd = 0, steps in Para. 10.6.3 must be followed.
2. Set rd parameter to value other than 0.
 - Follow steps in Para. 10.6.4

10.6.3 Set parameter rd, reveal depth = 0.

Step 15 Press 		Scroll to rd parameter.
Step 16 Press 		Displays "00", factory setting.
Step 17 Press 		"00" starts flashing.
Step 18 Press 		Scroll to "01".
Step 19 Press 		Scroll to "00".
Step 20 Press 		Saves value. Display stops flashing.
Step 21 Press 		Returns to reveal depth parameter.
Step 21		Go to Para. 10.7, Set door type parameter dL.

10.6.4 Set parameter rd to value other than 0.

Step 15 Press 		Scroll to rd parameter.
Step 16 Press 		Displays "00", factory setting.
Step 17 Press 		"00" starts flashing.
Step 18 Press 		Scroll to new value ("10" as example).
Step 19 Press 		Saves value. Display stops flashing.
Step 20 Press 		Returns to reveal depth parameter.
Step 21		Go to Para. 10.7, Set door type parameter dL.

Fine cover, Narrow header

Setup and Troubleshooting Instructions

Table 10.6.1 Reveal measurement and parameter rd values.

Reveal measurement			Reveal measurement			Reveal measurement			Reveal measurement		
Inches	[mm]	rd	Inches	[mm]	rd	Inches	[mm]	rd	Inches	[mm]	rd
-2 3/8"	-60	-6	4 3/4	120	12	11	280	28	16 1/8	410	41
-1 3/16	-30	-3	5 1/8	130	13	11 7/16	290	29	16 9/16	420	42
-3/4	-20	-2	5 1/2	140	14	11 13/16	300	30	16 15/16	430	43
-3/8	-10	-1	5 7/8	150	15	ED100/ED250 only.			17 5/16	440	44
0*	0	0	6 5/16	160	16	12 3/16	310	31	17 3/4	450	45
3/8	10	1	6 11/16	170	17	12 5/8	320	32	18 1/8	460	46
3/4	20	2	7	180	18	13	330	33	18 1/2	470	47
1 1/8	30	3	7 1/2	190	19	13 3/8	340	34	18 7/8	480	48
1 9/16	40	4	7 7/8	200	20	13 3/4	350	35	19 1/4	490	49
1 15/16	50	5	8 1/4	210	21	14 3/16	360	36	19 11/16	500	50
2 3/8	60	6	8 5/8	220	22	14 9/16	370	37			
2 3/4	70	7	9	230	23	15	380	38			
3 1/8	80	8	9 7/16	240	24	15 3/8	390	39			
3 1/2	90	9	9 13/16	250	25	15 3/4	400	40			
3 15/16	100	10	10 1/4	260	26						
4 5/16	110	11	10 5/8	270	27						

*rd factory setting = 0.

Fig. 10.6.2 Narrow header positive reveal

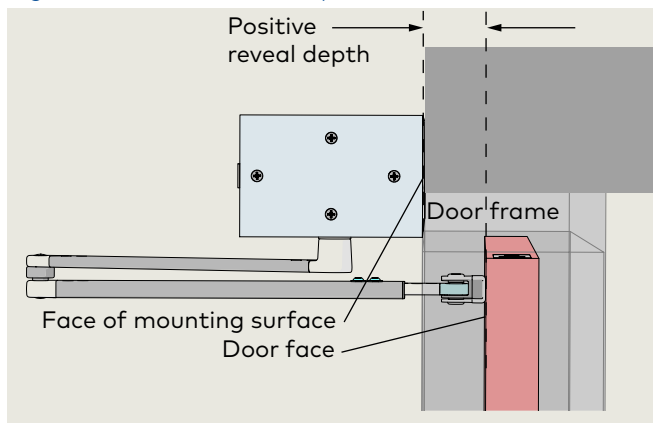

Fig. 10.6.3 Narrow header negative reveal,

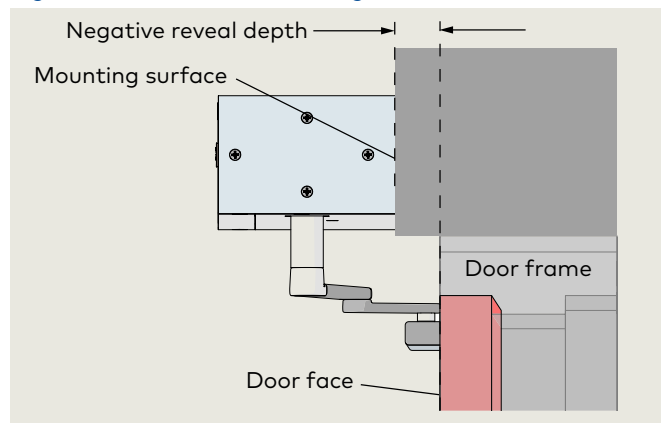

Fig. 10.6.4 Fine cover positive reveal

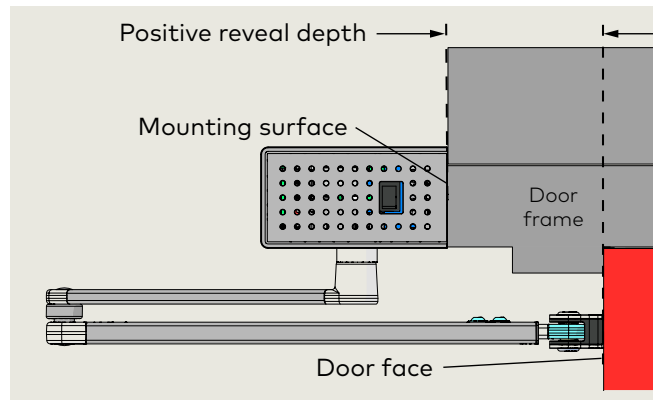
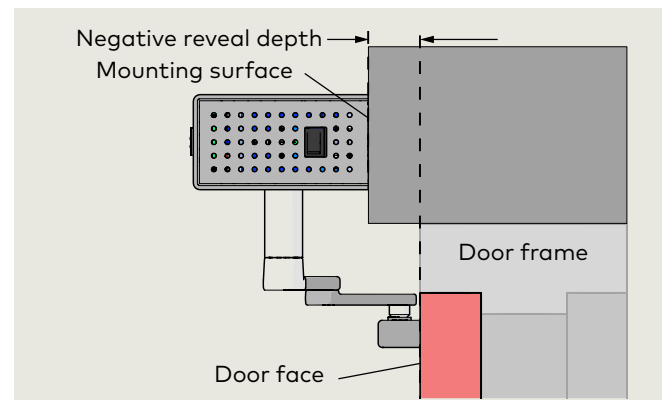



Fig. 10.6.5 Fine cover negative reveal



10.7 Set door type parameter dL

Table 10.7.1 Door type parameter dL values.

	Door type
Parameter value	Parameter description
0*	Single door
1	Pair doors, with astragal. Active door operator, door opens first.
2	Pair doors, with astragal. Inactive door operator.
3	Pair doors, without astragal. Active door operator. Both doors open simultaneously.
4	Pair doors, without astragal. Inactive door operator. Both doors open simultaneously.

*dL factory setting = 0.

10.7.2 Set dL door type parameter value.

NOTICE

1. **Set dL = 0** (single door =0).
 - "0" is dL factory setting.
 - **For system to recognize dL= 0, steps in Para. 10.7.3 must be followed.**

dL must be set to "0" for single door commissioning.

10.7.3 Set parameter dL, door type = 0.







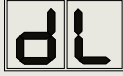
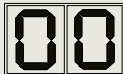

Step 22 Press ▼		Scroll to dL parameter.
Step 23 Press ▶		Displays "00", factory setting.
Step 24 Press ▶		"00" starts flashing.
Step 18 Press ◆		Scroll to "01".
Step 18 Press ◆		Scroll to "00".
Step 25 Press ▶		Saves value. Display stops flashing.
Step 26 Press ◀		Returns to door type parameter.
Step 27 Press ◀		Exits program mode.

Fig. 10.7.1 4 button keypad, 2 digit display

- 1 4 button keypad
- 2 2 digit display

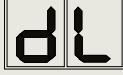

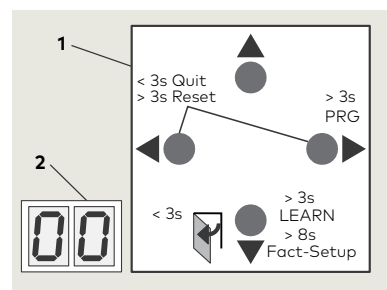
TIPS AND RECOMMENDATIONS

If display shows  after basic parameters have been set:

- Press ▼ for 3 seconds.
-  will be displayed.

Fine cover, Narrow header

Setup and Troubleshooting Instructions

10.8 Perform learning cycle

Fig. 10.8.1 Mode switch

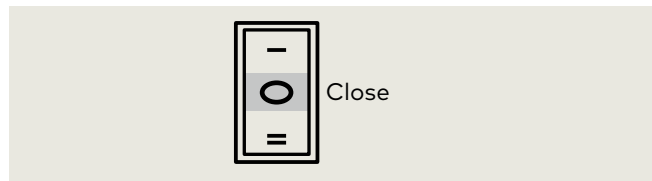

CAUTION

Learning cycle must be performed while motor is cold!

CAUTION

Door must not be manually moved or held in position during the learning cycle!

CAUTION

Verify that the following parameters have been set:

- **AS**, Installation type, Para. 10.4
- **rd**, Reveal depth, Para. 10.6
- **Tb**, Door width, Para. 10.5
- **dL**, Door type, Para. 10.7



TIPS AND RECOMMENDATIONS

During learning cycle:

- Operator functions are deactivated.





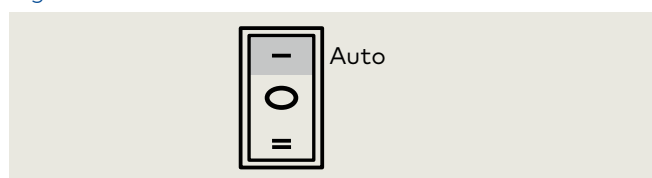

WARNING

No personnel or objects must be in range of door motion during learn cycle!

Fig. 10.8.2 Mode switch



Step 1	Secure motion range of door.
Step 2	Set Mode switch to CLOSE position,
	Rotating "o" and a "0" indicates operator learning cycle is required.
Step 3 Press ▼	<p>Press and hold down button until display changes.</p> <ul style="list-style-type: none"> • Door performs several movements and display shows a sequence of symbols. • Movements of door must not be interrupted!
	Display indicates door is at 70° position and is waiting for door opening angle to be set.
Step 4	<ul style="list-style-type: none"> • Manually move door to desired opening angle. • Maximum door angle is 110°.
Step 5 Press ▼	<p>Momentarily press down button to continue learning cycle.</p> <ul style="list-style-type: none"> • Door performs several movements and display shows a sequence of symbols. • Movements of door must not be interrupted!
	<p>Operator spring tension too low.</p> <ul style="list-style-type: none"> • Display with small rotating "o" and an "F" during learn cycle indicates spring tension is too low. • Door will close. <ol style="list-style-type: none"> 1. Increase spring tension (Para. 10.1). 2. Restart learning cycle (Step 3).
	<p>Door completes learning cycle.</p> <ul style="list-style-type: none"> • Display with two horizontal bars indicate operator is ready for operation.
Step 6 Press ▼	Momentarily press down button to cycle door.
Step 7	Following automatic learning cycle, actual forces on door, and door opening and closing times must be measured and changed if necessary to insure compliance with ANSI/BHMA standards, reference Chapter 17.
Step 9	Set Mode switch to Auto (Fig. 10.8.2).

Fine cover, Narrow header

Setup and Troubleshooting Instructions

10.9 Set power fail closing speed

- 1 Power fail closing speed potentiometer
- 2 Control board

Fig. 10.9.1 Power fail closing speed potentiometer

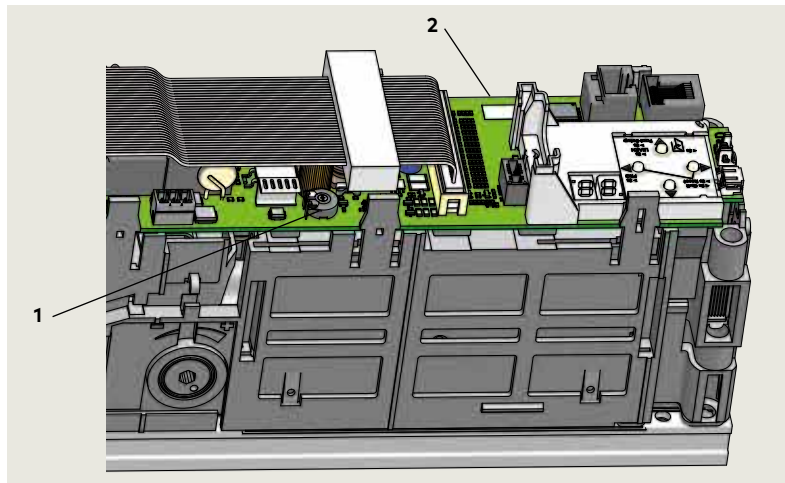

- 1 Power on switch
- 2 Terminal board

Fig. 10.9.2 Power on switch

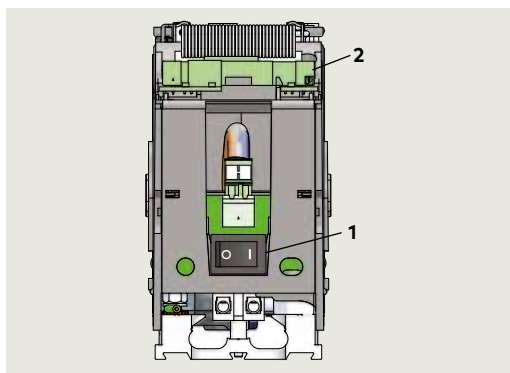

10.9.1 Power fail closing speed potentiometer.

- Single turn
- Factory setting: fully CCW
- CCW increases closing speed.
- CW decreases closing speed.
- 3/32" [2-3 mm] flat blade screwdriver required for adjustment.

10.9.2 Setting door closing speed upon power failure.

1. Turn power switch OFF.
2. Manually open door to 90° angle and let it close.
3. If door closes in less than 5 seconds, turn potentiometer 1/4 turn CW and retry test.
4. Continue retrying test after potentiometer adjustment until the door closing time is a minimum of 5 seconds.

NOTICE

Error message E73:

If door closes in less than three seconds, error message **E 73** (System error 3, braking circuit) will be displayed.

Reference: Appendix B, Troubleshooting.



TIPS AND RECOMMENDATIONS

Minimum 5 second closing time is required to meet requirements of:

- A117.1, Accessible and Usable Buildings and Facilities, Section 404.2.7.
- 2010 ADA Standards for Accessible Design, Section 404.2.8.

11 Initial setup – pair doors

11.1 Separately setup active and inactive doors

11.1.1 Setup active door first.

1. Refer to Chapter 10 and setup active door.

11.1.2 Setup inactive door.

1. Refer to Chapter 10 and setup inactive door.

11.2 Set operator parameters for pair door operation

11.2.1 Active door, set parameters dL and Ad.

1. Set active door Mode switch to CLOSE.
2. Set parameters **dL** (door type) and **Ad** (caster angle) for active door.
 - Caster angle sets opening angle of active door before inactive door starts to open. Factory setting is 30°.







CAUTION



Full width cover option.

Single program switch located on inactive door.

Table 11.2.1 Door type parameter dL values

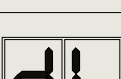
	Door type
Parameter value	Parameter description
0*	Single door
1	Pair door, with astragal. Active door operator, door opens first.
2	Pair door, with astragal. Inactive door operator.
3	Pair door, without astragal. Active door operator. Both doors open simultaneously.
4	Pair door, without astragal. Inactive door operator. Both doors open simultaneously.
*	Factory setting

Step 1 Press		Press and hold PRG > 3 s to enter program mode, AS parameter displayed.
Step 2 Press		Scroll to dL parameter.
Step 3 Press		Displays "00", factory setting.
Step 4 Press		"00" starts flashing.
Step 5 Press		Scroll to select parameter value ("1" as an example).
Step 6 Press		Saves value entered. Display stops flashing.
Step 7 Press		Returns to door type parameter.

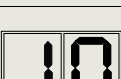
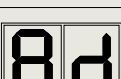
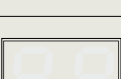



Step 8 Press		Scroll to Ad parameter.
Step 9 Press		Displays "30", factory setting.
Step 10 Press		Scroll to select parameter value (10° as an example).
Step 11 Press		Saves value entered. Display stops flashing.
Step 12 Press		Returns to caster angle parameter.
Step 13 Press		Exits program mode. Operator is ready for operation.

Fine cover, Narrow header

Setup and Troubleshooting Instructions

11.2.2 Inactive door, set parameter dL.





1. Set program switch to CLOSE.
2. Set parameter dL (door type) for inactive door.

Step 1 Press		Press and hold PRG > 3 s to enter program mode, AS parameter displayed.
Step 2 Press		Scroll to dL parameter.
Step 3 Press		Displays "00", factory setting.
Step 4 Press		"00" starts flashing.

NOTICE

Pairs must be:

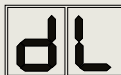
- 1 (active) and 2 (inactive) or
- 3 (active) and 4 (inactive).

Step 5 Press		Scroll to select parameter value ("2" as an example).
Step 6 Press		Saves value entered. Display stops flashing.
Step 7 Press		Returns to door type parameter.
Step 8 Press		Exits program mode. Operator is ready for operation.

11.3 Connect sync cable between operators

Fig. 11.3.1 Pair door operators, sync cable

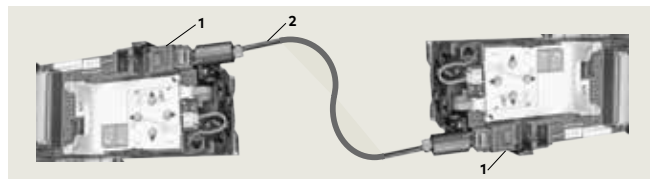

- 1 RJ45 jack (horizontal) for Sync cable
- 2 Sync cable DX3485-0X0

Fig. 11.3.2 RJ45 jack

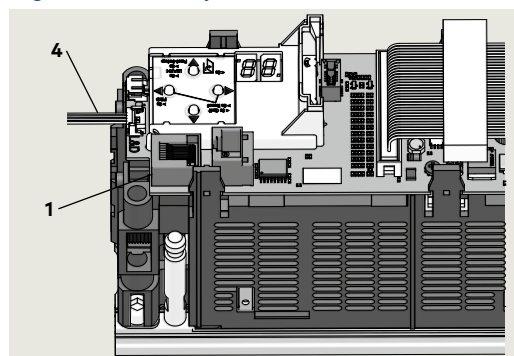

- 1 RJ45 jack
- 4 Mode switch cable

11.3.3 Sync cable lengths.

Sync cable	Length	Item #	Quantity
DX3485-030	80" [2030 mm]	1	1
Optional			
DX3485-010	9 7/8" [250 mm]	1	0
DX3485-020	40 1/2" [1030 mm]	1	0

11.3.1 Install Sync cable.

1. Set Mode switch to CLOSE.
2. Connect sync cable to active and inactive operator RJ45 jacks.
3. Secure cable to header.

11.3.2 Test door operation.

1. Set Mode switch to AUTO.
2. Test double door operation.
 - Use knowing act device.

Fig. 11.3.3 Mode switch, Close position

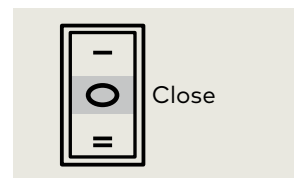

Fig. 11.3.4 Mode switch, AUTO position

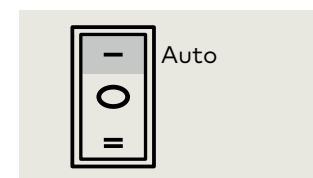

Fig. 11.3.5 Sync cable



12 Set track bumper stop

12.1 Set track bumper stop position

Fig. 12.1.1 Mode switch OPEN position

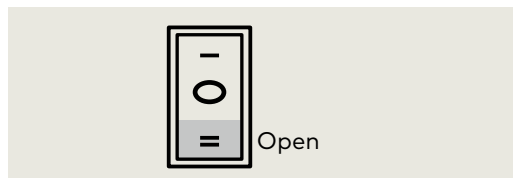

12.1.1 Set bumper stop position.

1. Set Mode switch to OPEN.
2. Door moves to set opening angle.



WARNING

Use caution when working in proximity of door and track.

3. Slide bumper and bumper stop toward slide shoe until bumper is 3/16" from edge of slide shoe (Fig. 12.1.2).
4. Tighten bumper stop M5 screw. Do not overtighten.

CAUTION

Using Mode switch, close then open door to verify gap between bumper and slide shoe with door at full open position.

Fig. 12.1.2 Setting bumper stop location, fine cover

- 1 Slide shoe
- 2 Bumper
- 3 Bumper stop
- 4 M5 x 13 FHMS cross recessed

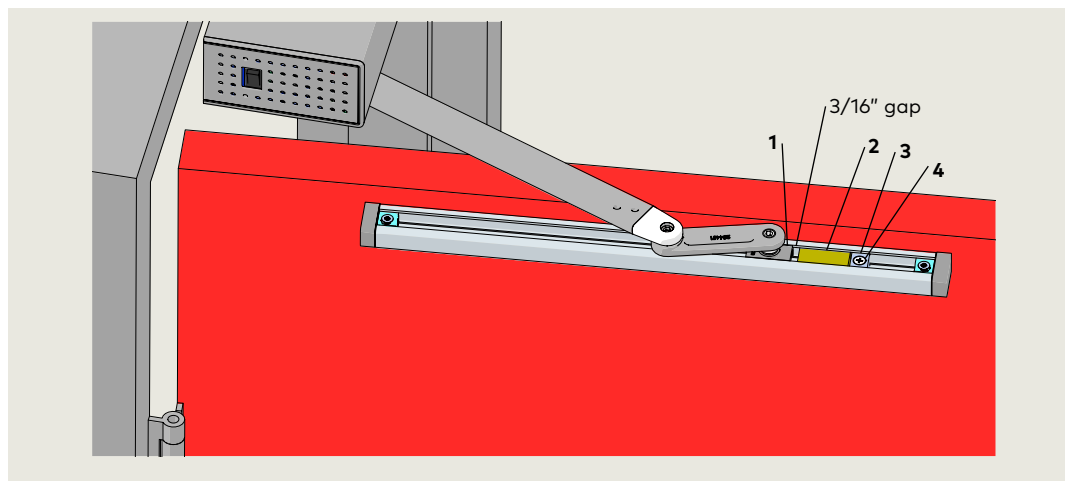
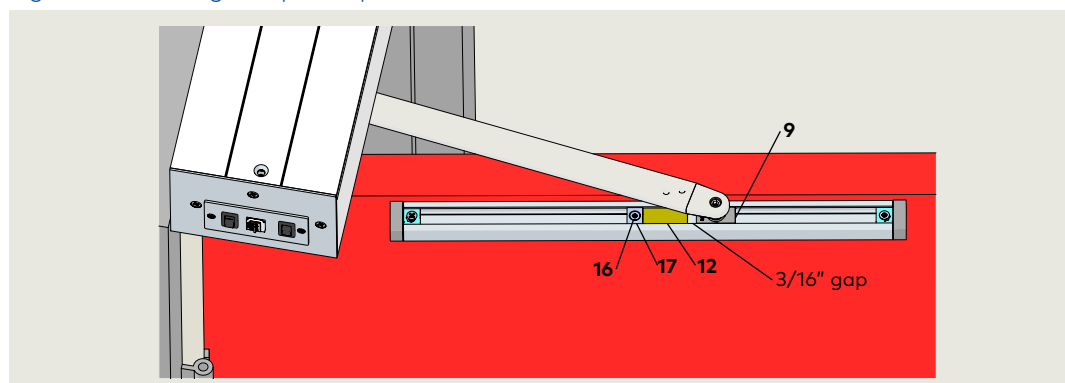

Fig. 14.1.3 Setting bumper stop location, narrow header

- 9 Slide shoe
- 12 Bumper
- 16 MM5 x 13 FHMS cross recessed
- 17 Bumper stop



13 Install push arm door stop

13.1 Install push arm door stop (optional assembly)

- 1 1/2" thick base plate
DC4633-002
- 2 1/4" thick base plate
DC4633-001
- 3 Rubber bumper
DC4633-003
- 4 Shoulder screw
DC4633-004

Fig. 13.1.1 Door stop assembly

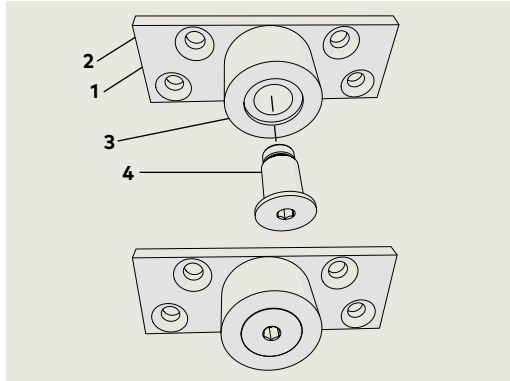

TIPS AND RECOMMENDATIONS

Contact local dormakaba USA, Inc. company for door stop assembly HS4633-001

13.1.1 Assemble bumper stop.

1. Attach bumper to bumper mounting plate with 1/2" shoulder screw.
 - Use 5 mm hex key.

13.1.2 Open door.

1. Set Mode switch to OPEN position.
2. Door moves to set opening angle.



WARNING

Use caution when working in proximity of door and push arm!.

Fig. 13.1.2 Mode switch OPEN position

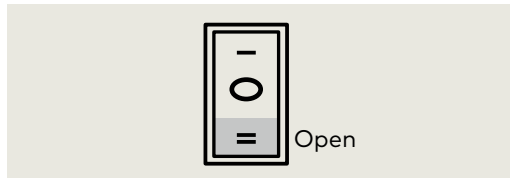

- 5 Mounting screw kit
HC4633-005
- 5.1 1/4 x 1 1/4" Phillips FHS, black oxide, SS
- 5.2 No. 14 x 1 1/4" Phillips FHS for sheet metal, zinc plated steel

Fig. 13.1.3 Door stop fasteners

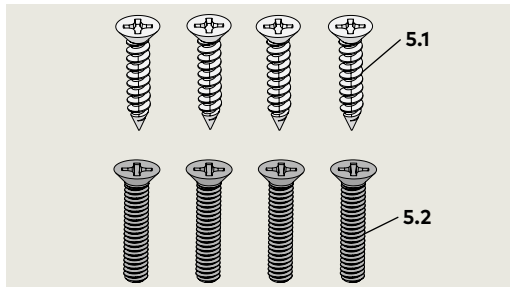

13.1.3 Bumper stop installation.

1. With door at its full open position locate door stop assembly bumper on door frame 1/8" beyond arm.
2. Mark mounting plate hole locations on frame.
 - Plate hole diameter is 1/4".
3. Select fasteners based on door frame material.
4. Attach door stop assembly to frame.

Fig. 13.1.4 Door stop installation, narrow header

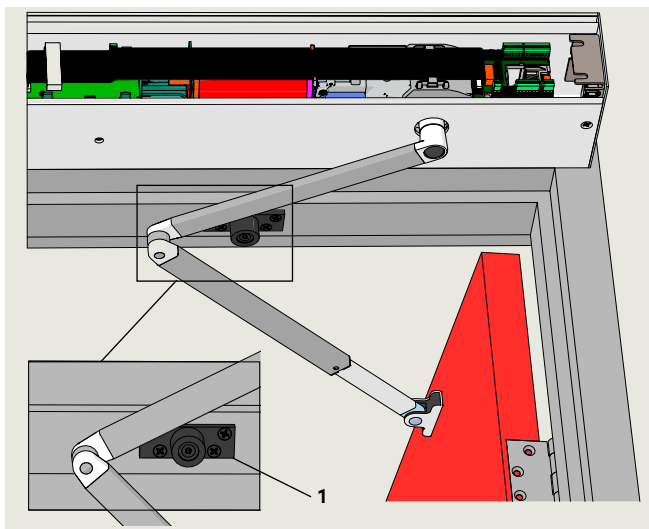

- 1 Bumper stop assembly

CAUTION

Using Mode switch, close then open door to verify arm does not contact door stop with door at full open position.

Fig. 13.1.5 Door stop installation, fine cover

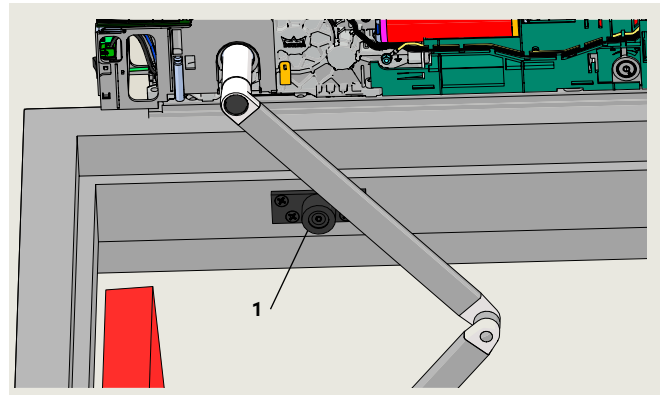

14 Check door signage

14.1 Check door signage

14.1.1 Check door signage.

Check door signage as outlined in ED50/ED100/ED250 (Fine cover) or ED50/ED100/ED250 (Narrow header) Installation Instructions.

15 Install cover, end caps and spindle caps

15.1 Install fine cover and end caps

Fig. 15.1.1 ED100/ED250 standard cover

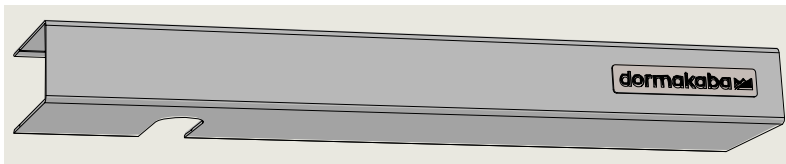
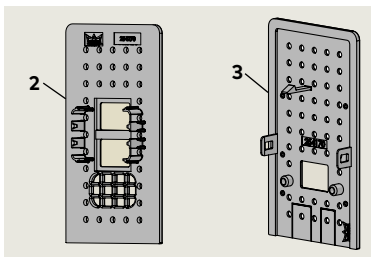
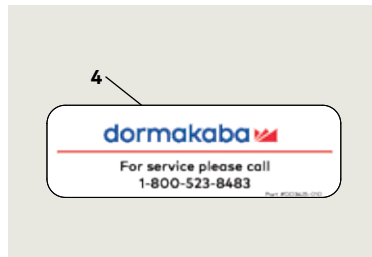

Fig. 15.1.2 Operator end caps



- 2 Mode, Exit Only switches
- 3 Power switch

Fig. 15.1.3 Service Call label



- 4 Service Call label DD3425-010

Fig. 15.1.4 Cover and end cap installation

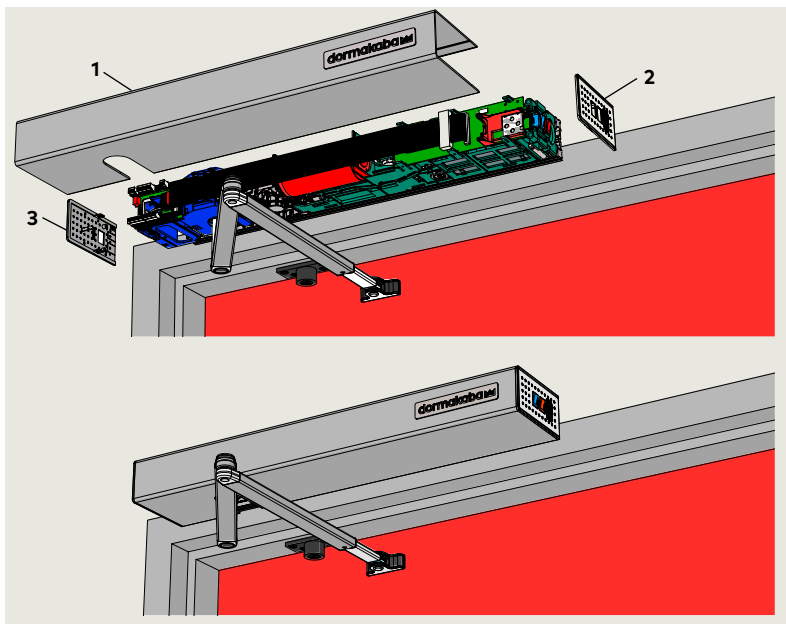

- 1 ED100/ED250 standard cover
- 2 End cap, Mode and Exit Only switches
- 3 End cap, power switch

15.1.1 Install Service Call label.

1. Install Service Call label (Fig. 15.1.3) at convenient location.

15.1.2 Install cover.

1. Align cover with operator, press inward until cover snaps into place.

CAUTION

Insure that all cables are in place and secured.



TIPS AND RECOMMENDATIONS

For optional full width cover installation, go to ED50/ED100/ED250 Installation Instructions

15.1.3 Install end caps.

1. Install operator end caps.



TIPS AND RECOMMENDATIONS

Mode switch end cap; insertion depth is adjustable to compensate for minor tolerances is length of operator cover.

Fine cover, Narrow header

Setup and Troubleshooting Instructions

15.2 Install spindle caps, fine cover

- 4 Spindle cap
- 5 Spindle cap

Fig. 15.2.1 Spindle caps

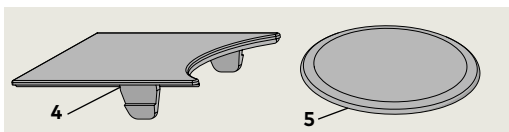
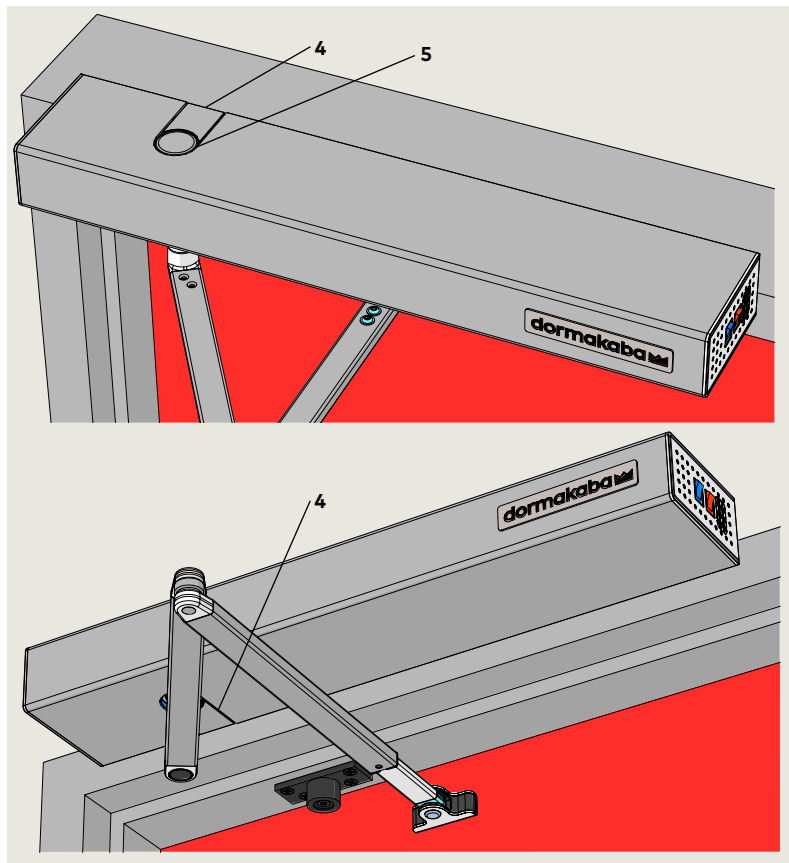

Fig. 15.2.2 Spindle cap installation



- 4 Spindle cap
- 5 Spindle cap

15.3 Install narrow header cover

Fig. 15.3.1 Single door narrow header with cover installation

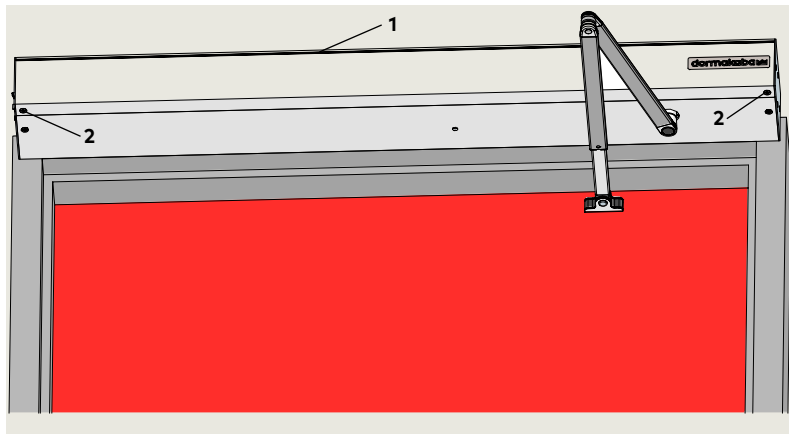

- 1 Header cover
- 2 Flat head screw

15.2.1 Install spindle caps.

1. Install spindle caps on cover.

15.1.1 Install Service Call label.

1. Install Service Call label (Fig. 15.1.3) at convenient location.

15.1.2 Install narrow header cover.

CAUTION

Before installing cover, check header assembly:

- All wiring secured.
- No pinched wiring.
- Remove any debris in header; assembly must be clean.

2. Install narrow header cover on header and secure with supplied flat head screws.

Note: Narrow header with push arm shown as an example.

16 Upgrade cards

16.1 Upgrade cards, ED50/ED100/ED250

16.1.1 Upgrade card installation.

dormakaba upgrade cards can be used to expand the range of functions of ED50/ED100/ED250 operators. When upgrade cards are installed, information is exchanged between and permanently allocated to both the operator control unit and the upgrade card.

Fig. 16.1.1 Upgrade card slot

- 1 Upgrade card slot
- 2 Upgrade card socket
- Status LEDs
- 3 Green LED
- 4 Yellow LED
- 5 Red LED
- 6 Upgrade card

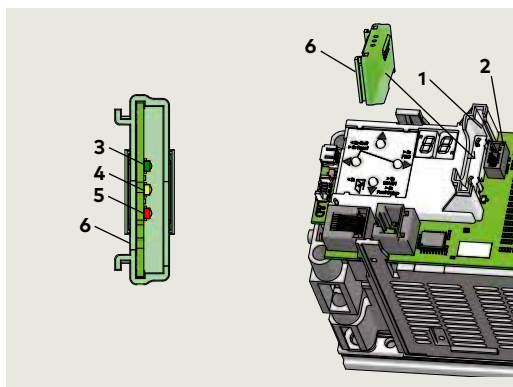

Table 16.1.1 Upgrade cards

Upgrade card		Part No.	Color
Fire protection	ED50/ ED100	DX3461-003	Red
	ED250	DX3461-004	Transparent red
DCW	ED50/ ED100/ ED250	DX3461-007	Yellow
Barrier free toilet	ED50/ ED100/ ED250	DX3461-006	Dark green

16.2 Container module

16.2.1 Container module

- The first upgrade card installed becomes the container module.
- Every operator control unit has only one container module.
- Functions of upgrade cards installed after the first upgrade card are saved in the container module.

16.2.2 Container module removal.

- If the container module is removed, all previously enabled functions will be deactivated **after a certain time**.

16.2.3 Operator control unit replacement.

- If the control unit is replaced, the container module is removed from the old control unit and inserted into the new control unit.
- The new control unit synchronizes with the container module and all upgrade card functions are available.

16.2.4 Inserting an upgrade card that has already been activated.

- Rapidly flashing yellow LED on upgrade card indicates card is rejected.
- Card's functions in operator control unit are still valid.

16.2.5 Inserted a container module from third party control unit.

- Rapidly flashing yellow and green LEDs on container module indicates module is rejected.
- Container module can only be synchronized with one control unit.

16.2.6 Container module defective.

- Upgrade cards that were installed after the container module must be reinstalled.

16.3 Installing upgrade cards

16.3.1 Set Mode switch to CLOSE.

- 1 Upgrade card slot
- 6 Barrier free toilet upgrade card
- 7 Container module
- 8 Mode switch
- 9 2 digit display with horizontal bars

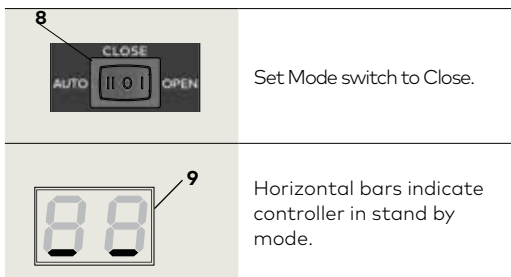

16.3.2 Installing first upgrade card.

- 1 Upgrade card slot
- 2 First upgrade card

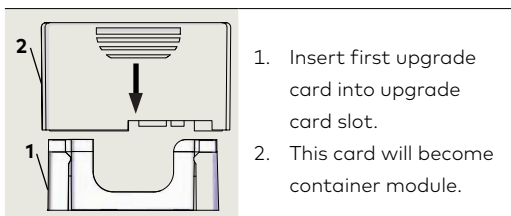

- 4 Yellow LED
- 7 Container module

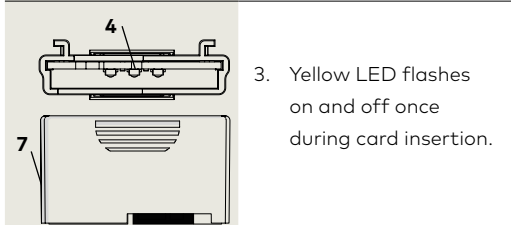

- 1 Upgrade card slot
- 3 Green LED
- 7 Container module

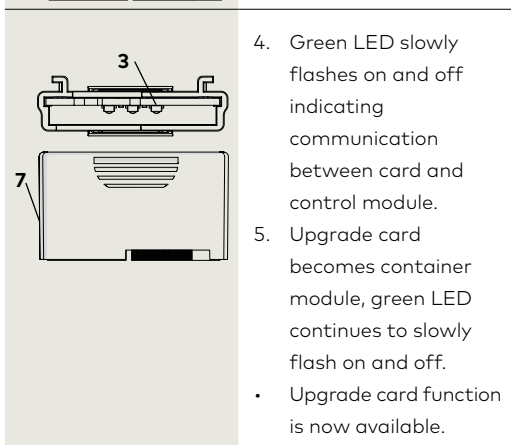

- 3 Green LED
- 7 Container module



TIPS AND RECOMMENDATIONS

Container module can be configured using applicable parameter (F1 - F8) for card. Reference Chapter 9, Parameters.

16.3.3 Installing additional upgrade cards.

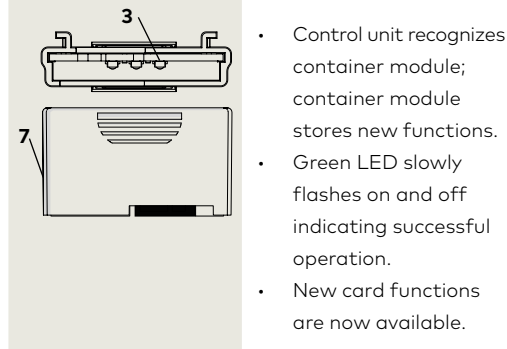
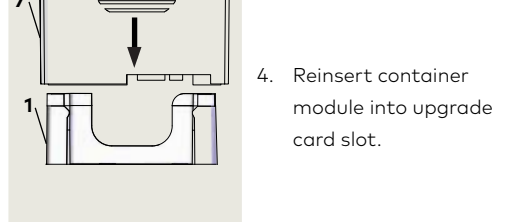
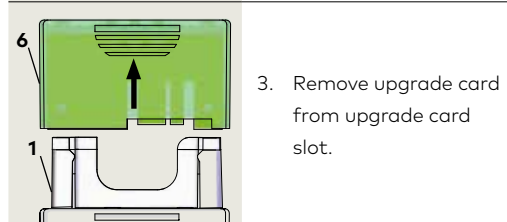
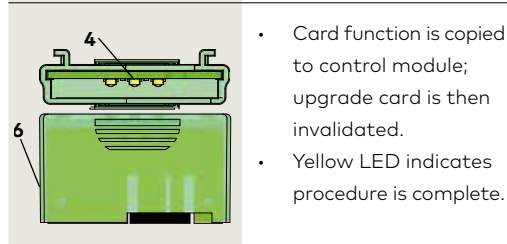
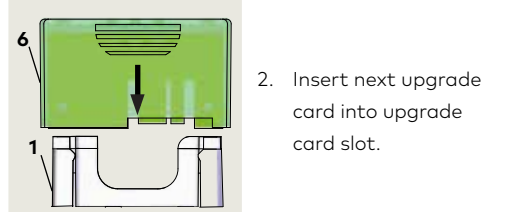
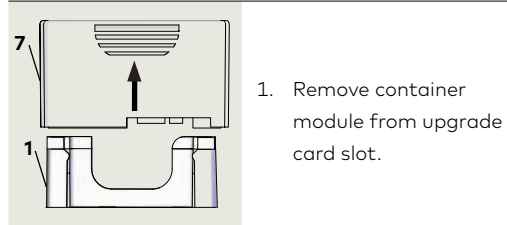

TIPS AND RECOMMENDATIONS

New upgrade card can be configured using applicable parameter (F1 - F8) for card. Reference Chapter 9, Parameters.

17 ANSI/BHMA standards

17.1 Power operated pedestrian doors (ANSI/BHMA 156.10)

The following table references portions of content from ANSI/BHMA A156.10. Refer to the standard, available through ANSI or BHMA for additional information. Standard material reprinted with BHMA permission.

17.1.1 Door measurements, power operated swing door.

		ED100/ED250 Parameter			A156.10 standard	
Parameter	Function	Factory setting	Adjustment range	Para.	Requirement	
So	Opening speed automatic mode	Swing door opening speed, automatic mode.	25%/s	8%/s - 60%/s	10.2.1	Opening time of a swing door to 80°, not less than 1.5 s.
Sc	Closing speed automatic mode	Swing door closing speed, automatic mode.	25%/s	8%/s - 60%/s	10.2.5	Closing time of a swing door to latch check. Ref. Para. 19.1.2.
Fo	Static force in opening direction	Static force on door closing edge in opening direction.	Parameter setting *10 [60 N] 13.5 lb f	Parameter setting *10 20 N - 130 N 4.5 lb f - 29.8 lb f	10.2.2	Shall not exceed 30 lb f [133 N] measured 1" from lock edge of door.
Fc	Static force in closing direction	Static force on door closing edge in closing direction.	Parameter setting *10 [60 N] 13.5 lb f	Parameter setting *10 20 N - 130 N 4.5 lb f - 29.8 lb f	10.2.7	Not to exceed 30 lb f [133 N] measured 1" from lock edge of door at any point in closing cycle.
bc	Backcheck	Checking or slowing down of door speed before door being fully opened.	10°	5° - 40°	10.2.3	Shall occur at no less than 10° of full open position.
dd	Hold open time	Open time for swing doors using sensors or control mats upon loss of detection.	5 s	0 s - 30 s 0 s - 180 s F2 = 2.	10.2.4	Shall remain open a minimum of 1.5 seconds after loss of detection.
	Latch check	Checking or slowing down of door speed before door being fully closed.		Not adjustable	10.2.6	Shall occur for a swinging door at no less than 10° from closed position. The door will not close through the final 10° in less than 1.5 s.
hS	Reference Appendix B for parameter detail	Support for manual mode in door closed position.			10.2.8	Manual opening force in event of power failure. Swing door shall be capable of being opened manually with no greater than 30 lb f applied 1" from edge of lock style to open.
hA		Adjustment, door activation angle.				
hF		Power assist function.				

17.1.2 A156.10, 10.2.5 swing door closing time to latch check.

"D" door width, minimum (inches)	"W" door weight, maximum (pounds)	"T" closing time, minimum, to latch check (seconds)
36 or less	100	2.0
36	140	2.3
42	110	2.3
42	150	2.7
48	120	2.8
48	160	3.2

17.1.3 Other door weights and widths.

"D" door width, minimum (inches)	"W" door weight, maximum (pounds)	"T" closing time, minimum to latch check (seconds)
48	160	3.2

Closing time $T = (D \sqrt{W}) / 188$

D = Width of door in inches.

W = Weight of door in pounds.

T = Closing time to latch check in seconds.

Fine cover, Narrow header

Setup and Troubleshooting Instructions

17.2 Low energy power operated doors (ANSI/BHMA A156.19)

The following table references portions of content from ANSI/BHMA A156.19. Refer to the standard, available through ANSI or BHMA for additional information. Standard material reprinted with BHMA permission.

17.2.1 Door measurements, low energy power operated door.

		ED50/ED100/ED250 Parameter			A156.19 standard	
Parameter	Function	Factory setting	Adjustment range	Para.	Requirement	
So	Opening speed	Swing door opening speed, automatic mode.	25%/s	8%/s - 27%/s	4.3	Opening Doors shall open from closed to back check or 80°, whichever occurs first, in 3 seconds or longer as required in Table I. Total opening time to 90° shall be as in Table II (next page) If door opens at more than 90°, it shall continue at the same rate as backcheck speed.
bc	Backcheck	Checking or slowing down of door speed before door being fully opened.	10°	5° - 40°	4.3	Backcheck shall not occur before 60° opening.
Sc	Closing speed	Swing door closing speed, automatic mode.	19%/s	8%/s - 27%/s	4.5	Closing Doors shall close from 90° to 10° in 3 s or longer as required in Table I (next page). Doors shall close from 10° to fully closed in not less than 1.5 s.
dd	Hold open time	Hold open time	5 s	5 s - 30 s	4.4	Time delay When powered open, the door shall remain open at the fully opened position for not less than 5 s. Exception: when push-pull activation is used, the door shall remain at the fully opened position for not less than 3 s.
hS	Reference Appendix A for parameter detail.	Support for manual mode in door closed position.			4.6	Reference ANSI/BHMA A156.19, Para. 4.6, Force and Kinetic Energy.
hA		Adjustment, door activation angle.				
hF		Power assist function.				
Fo	Static force in opening direction	Static force on door closing edge in opening direction.	Parameter setting *10 60 N 13.5 lb f	Parameter setting *10 20 N - 60 N 4.5 lb f - 13.5 lb f	4.6	The force required to prevent a stopped door from opening or closing shall not exceed 15 lb f [67 N] measured 1" from latch edge of the door at any point during opening or closing.
Fc	Static force in closing direction	Static force on door closing edge in closing direction.	Parameter setting *10 60 N (*10) 13.5 lb f	Parameter setting *10 20 N - 60 N (*10) 4.5 lb f - 13.5 lb f	4.6	

Note 1: Speed may be slower after learning cycle completed.

Fine cover, Narrow header

Setup and Troubleshooting Instructions

17.2.2 A156.19, Table I: Minimum opening and closing times.

"D" door width, inches	"W" door weight, pounds				
	100	125	150	175	200
30	3.0 s	3.0 s	3.0 s	3.0 s	3.5 s
36	3.0 s	3.5 s	3.5 s	4.0 s	4.0 s

Minimum opening time to back check or 80 degrees (whichever occurs first).
 Minimum closing time from 90 degrees to latch check or 10 degrees (whichever occurs first).

17.2.3 A156.19, Table II: Total opening time to 90 degrees.

Back check at 60°	Back check at 70°	Back check at 80°
Table I plus 2 s	Table I plus 1.5 s	Table I plus 1 s

If door opens more than 90°; it shall continue at the same rate as back check speed.

Back check occurring at a point between positions shall use lowest setting.

17.2.4 Other door weights and widths

Closing time $T = (D \sqrt{W}) / 188$

D = Width of door in inches.



W = Weight of door in pounds.

T = Closing time to latch check in seconds.

Appendix A - Driving parameters

A.1 Driving parameters – detail





A.1.1 Driving parameters detail.

Parameter	Value range	Units	Factory setting	Description
Opening speed, automatic mode				
5	ED50 8- 27*	%s	25	<p>ED50: low energy only. *ED50 adjustable opening speed range.</p> <p>ED100/ED250 Full adjustable range of opening speeds available only when configured for full energy (Parameter F2). **Maximum opening speed reduced to 27%/s in low energy mode.</p> <ol style="list-style-type: none"> After adjustment, internal monitoring system checks if parameter setting is admissible. If setting exceeds admissible value, the setting is alternately displayed with the permissible value. After adjustment, Internal monitoring system checks if parameter setting is admissible. If setting exceeds admissible value, the setting is alternately displayed with the permissible value. After parameter set, verify setting meets ANSI/BHMA standards A156.10 (full energy) or A156.19 (low energy) standards. Reference Chapter 19.
	 ED100 2- 50**	%s		
	ED250 2 - 60**	%s		
Closing speed, automatic mode				
5	ED50 8- 27*	%s	25	<p>ED50: low energy only. *ED50 adjustable closing speed range.</p> <p>ED100/ED250 Full adjustable range of closing speeds available only when configured for full energy (Parameter F2). **Maximum closing speed reduced to 27%/s in low energy mode.</p> <ol style="list-style-type: none"> After adjustment, internal monitoring system checks if parameter setting is admissible. If setting exceeds admissible value, the setting is alternately displayed with the permissible value. After adjustment, Internal monitoring system checks if parameter setting is admissible. If setting exceeds admissible value, the setting is alternately displayed with the permissible value. After parameter set, verify setting meets ANSI/BHMA standards A156.10 (full energy) or A156.19 (low energy) standards. Reference Chapter 19.
	 ED100 2- 50**	%s		
	ED250 2 - 60**	%s		
Hold open time, automatic mode				
7	0 - 30	s	5	<ul style="list-style-type: none"> Hold open time starts once all internal, external, safety and push and go inputs have been opened or dropped, and door is in an open position; Hold open time can be re-triggered. Hold open time values from 0 to 30 are set in increments of 1 second. *Parameter F2, when set to full energy, extends maximum hold open time to 180 seconds. Hold open time values greater than 30 seconds are set in increments of 5 seconds.
	0 - 180*	s		

Fine cover, Narrow header

Setup and Troubleshooting Instructions







A.1.1 Driving parameters detail.

Parameter	Value range	Units	Factory setting	Description	
Night-bank hold open time					
8	 0 - 30	s	10	<ul style="list-style-type: none"> Night-bank (key switch) hold open time is set using this parameter. Night-bank Hold open time starts once contact on night-bank activator input is opened and door is in an open position; Night-bank hold open time can be re-triggered. 	
Hold open time, manual opening					
9	 0 - 30	s	1	<ul style="list-style-type: none"> Default hold open time of 1 second that follows every manual opening of door can be adjusted using parameter do. Hold open time starts when door is released. 	
Wall masking on door hinge side					
10	 60 - 99	°	80	<ul style="list-style-type: none"> Wall masking required if door opens against an obstacle. When door reaches set wall masking angle, system will ignore signal from safety sensor on door swing (hinge) side. The wider the detection range of safety sensor used, the greater the area must be in which system has to ignore sensor's emitted signal. To insure personnel safety, it is advised to keep this range as small as possible. If set wall masking angle is exceeded when door is being opened, a rapidly flashing dot appears in top left hand corner of 2 digit display. Rapidly flashing dot disappears when door angle drops below set wall masking angle. 	
Safety sensor test					
				Safety sensor parameter ST must be set to sensors used and if they are active-high or active-low. See E 04 safety sensor test error, Appendix B.	
11		0 - 8	0	0	Sensor test off.
				1	Sensor test on swing (hinge) side. Active-high
				2	Sensor test on swing and approach sides. Active-high
				3	Sensor test on swing and approach sides. Active-high
				4	Sensor test on swing side. Active-low
				5	Sensor test on approach side. Active-low
				6	Sensor test on swing and approach sides. Active-low
				7	Wall mounted sensor with data line. Lock monitoring not available.
				8	Sensor test overhead sensor type Bodyguard III or Premier T with monitoring input.
Activation by safety sensor on approach (opposite hinge) side					
12		0 - 1	0	0	Safety sensor's input is disregarded as soon as door is closed.
				1	Safety sensor can trigger an opening pulse while door is closed.

Fine cover, Narrow header

Setup and Troubleshooting Instructions





A.1.1 Driving parameters detail.

Parameter	Value range	Units	Factory setting	Description
Suppression of safety sensor on swing (hinge) side during initialization drive				
13	 0 - 1		0	<p>0 Safety sensor on swing side is active during an initialization drive after a power on reset.</p> <p>1</p> <ul style="list-style-type: none"> With SP set to 1, operator will disregard swing side safety sensor during initialization drive. After a power on reset, operator starts an initialization drive at slow speed. The initialization drive cannot be completed if safety sensor on hinge side is, or has been triggered.
Delayed opening time for locking mechanism				
14	 0 - 40 *100	ms	3 *100	<ul style="list-style-type: none"> Delayed opening time delay starts as soon as door opening pulse has been generated. Door opens on expiration of time delay. If parameter is set to "0" and input for locking feedback contact is closed, door will not perform a preload Pu before door unlocks. Since various motor locks do not have feedback contacts, a delay of up to 4 seconds is possible
Door preload prior to unlocking				
15	 0 - 9		0	<ul style="list-style-type: none"> Door preload prior to unlocking; force with which door is pushed in the "closed" direction before door is opened. The door may need to be pushed in closing direction (preload) in order to release electric strike to insure door opens. Preload time is set by parameter Ud, delayed opening time for locking mechanism. To maintain long service life, set preload force only as high as necessary.
Power reserve module SVP-PR 12 test				
16	 		0	<p>0 Test off</p> <p>1</p> <ol style="list-style-type: none"> SVP-PR 12 power reserve module test is performed once every 24 hours, or 10 minutes after AC power has been turned on. In event of an error: <ul style="list-style-type: none"> Unlocking is not performed and no automatic door movements are initiated. Error code E 25 is displayed, See Appendix B, troubleshooting error codes. SVP-PR 12 power reserve module can be used but must be tested on a regular basis if using: <ul style="list-style-type: none"> SVP-2000 DCW emergency escape motor lock with automatic latching action. M-SVP 2000 DCW emergency escape lock. Test is automatically activated if a fire protection module is recognized in conjunction with SVP-2000 DCW or M-SVP 2000 DCW locks.
Static force in opening direction				
17		<p>Low Energy ANSI/BHMA A156.19</p> <p>Parameter setting *10 20N - 60N 4.5 lbf - 13.5 lbf</p> <p>Full Energy ANSI/BHMA A156.10</p> <p>Parameter setting *10 20N - 130N 4.5 lbf - 29.8 lbf</p>	6 6	<p>ED50: Low energy only. ED100/ED250: can be configured for full energy using Parameter F2.</p> <ul style="list-style-type: none"> Static force in opening direction (basic parameter for wind load control). Static force on door closing edge can be changed using this parameter. After parameter adjustment, internal monitoring system checks if parameter setting is admissible. If setting exceeds admissible value, the setting is alternately displayed with the permissible value. <p>1. After parameter set, verify setting meets ANSI/BHMA standards. See Chapter 19.</p>

Fine cover, Narrow header

Setup and Troubleshooting Instructions





A.1.1 Driving parameters detail.

Parameter	Value range	Units	Factory setting	Description	
Static force in closing direction					
17		Low Energy ANSI/BHMA A156.19 Parameter setting *10 20N - 60N 4.5 lbf - 13.5 lbf	6	ED50: Low energy only. ED100/ED250: can be configured for full energy using Parameter F2. <ul style="list-style-type: none"> Static force in closing direction (basic parameter for wind load control). Static force on door closing edge can be changed using this parameter. After parameter adjustment, internal monitoring system checks if parameter setting is admissible. If setting exceeds admissible value, the setting is alternately displayed with the permissible value. 1. After parameter set, verify setting meets ANSI/BHMA standards. See Chapter 19.	
		Full Energy ANSI/BHMA A156.10 Parameter setting *10 20N - 130N 4.5 lbf - 29.8 lbf	6		
Motor driven latching action, automatic mode					
19		0 - 9	0	<ul style="list-style-type: none"> System offers a motor driven latching action in automatic mode in addition to mechanical latching action. Static force in opening direction (basic parameter for wind load control). Low energy operator (ANSI/BHMA A156.19): static force range is reduced. The EP parameter setting is designed to increase static force on door closing edge to insure proper closing despite resistance caused by door seals or locking devices. 1. After EP parameter set, verify setting meets ANSI/BHMA standards. See Chapter 19. <ul style="list-style-type: none"> After parameter adjustment, internal monitoring system checks if parameter setting is admissible. If setting exceeds admissible value, the setting is alternately displayed with the permissible value. 2. Setting should be increased step by step from a low setting so as to avoid damage to the system. Use the lowest possible setting. <ul style="list-style-type: none"> Ensure that both the door itself and the push or pull arm installation are suitable for the additional, permanent forces. 	
Motor driven latching action angle					
20		2 - 10	°	3	Door opening angle at which motor driven latching action EP is activated. <ul style="list-style-type: none"> Starting angle of the latching angle adjustable from 10°.
Keep closed force					
21		0 - 9		0	0 Off <ul style="list-style-type: none"> Keep closed force can be set from 0 (off) to 9, maximum force. Keep closed force is: 1 to 9 <ul style="list-style-type: none"> Permanently applied following motor drive latching action. Designed to keep door in closed position even if wind acts on door.
Push & Go					
22		0 - 1		0	0 Off <ul style="list-style-type: none"> Door close mode parameter hd must be set to "0" (automatic) to enable this function. 1 <ul style="list-style-type: none"> When set to 1, parameter is activated. Automatic opening of door is started when door is manually moved 4° out of the closed position.

Fine cover, Narrow header

Setup and Troubleshooting Instructions





A.1.1 Driving parameters detail.

Parameter	Value range	Units	Factory setting	Description
Mode switch type				
23		0 - 4	0	0 Internal, operator mounted mode switch is active.
				1 External mechanical mode switch with contacts is connected to operator terminal board. Internal mode switch connector must be removed.
				2 External DCW electronic mode switch (EPS) is connected to operator terminal board. Internal mode switch connector must be removed.
				3 Mode switch control by TMS Soft control software.
				4 <ul style="list-style-type: none"> DCW Mode switch (EPS) is installed, and operator is also connected by the building management system to TMS Soft control software. When PS is set to 4, the Mode switch functions can be changed from DCW (EPS) to TMS Soft..
DCW® Electronic mode switch (EPS) behavior following power reset				
24		0 - 1	0	0 <ul style="list-style-type: none"> In event of power failure, or if operator is deliberately switched off, EPS will automatically switch to last known position when power returns. Important: The time at which power returns might not be during business hours and may affect insurance-compliant door locking requirements.
				1 <ul style="list-style-type: none"> In event of power failure, or if operator is deliberately switched off, EPS will automatically switched to OFF position when power returns. This function should be used iif insurance compliant locking if required.
Internal program switches, switch on delay				
25		0 - 1	0	0 Operator will perform function of new switch setting as soon as internal program switch is moved.
				1 <ul style="list-style-type: none"> Operator will perform function of new switch setting after a delay of 10 seconds from when internal program switch is moved. This function is useful if user has to pass through door and its connected detectors and sensors after program switch is set to new function.
Unlocking during business hours				
26		0 - 1	0	0 Door is always locked when it reaches closed position.
				1 <ul style="list-style-type: none"> In automatic mode, door will not lock when it reaches closed position. This achieves faster door opening when system is equipped with motor driven locks. If an electric strike opener is used, it must be suitable for 100% continuous duty factor to avoid possibility of damage.

Fine cover, Narrow header

Setup and Troubleshooting Instructions





A.1.1 Driving parameters detail.

Parameter	Value range	Units	Factory setting	Description
Status relay function, X7 terminals				
27		0 - 6	1	0 Status relay is deactivated.
				1 Status relay activated as soon as door reaches door "closed" position.
				2 Status relay activated as soon as door reaches door "open" position.
				3 Status relay activated when error codes are displayed on 2 digit operator display.
				4 "Door closed and locked" activates status relay.
				5 Status relay activated when information or error codes are displayed on 2 digit operator display.
				6 <ul style="list-style-type: none"> Status relay activated when door is opened further than opening angle parameter OA, set during learning cycle. Parameter OA value can only be changed using dormakaba handheld or by performing another learning cycle.
Locking device output configuration; output X3, 1G (24V) and input X6, 4/4a				
Reference Chapter 8.				
28		0 - 1	0	0 Locking device output terminal X3, 1G (24V) is independent of Input X6, 4/4a.
				1 <ul style="list-style-type: none"> Locking device output terminal X3, 1G (24V) is turned on as soon as contact at X6, 4/4a is opened.. Terminal X3, 1G 24V output is on for as long as contact at X6, 4/4a is open, motor lock with a 100% duty factor is required. This function is not available for DCW motor locks.
Cycle counter				
29		0 - 99 * 10000	cycles	<ul style="list-style-type: none"> Total number of opening and closing cycles displayed is shown in increments of 10000; Display value, "4", 40,000 cycles, Display value, "53", 530,000 cycles. Total number of cycles can be displayed on dormakaba handheld. A display value of "99" means 990,000 cycles or greater.
Delete error log				
30		0 - 1	0	0 No function.
				1 <ol style="list-style-type: none"> When "1" entered, Error log is deleted. <ul style="list-style-type: none"> Parameter is then automatically reset to "0".
Reset service interval display, operator yellow LED				
31		0 - 1	0	0 No function.
				1 <ol style="list-style-type: none"> When "1" entered: <ul style="list-style-type: none"> Service cycle counter is reset to 200,000. Service interval is reset to 12 months. Yellow LED not illuminated. Parameter is then automatically reset to "0". Values other than default values must be set using dormakaba USA, Inc. handheld: <ul style="list-style-type: none"> Maintenance interval Maintenance cycles

Fine cover, Narrow header

Setup and Troubleshooting Instructions







A.1.1 Driving parameters detail.

Parameter	Value range	Units	Factory setting	Description
Factory setting level.				Parameter SL is used to determine what data will be reset during factory setting process.
32	 1 - 2		1	<p>Standard factory settings.</p> <ol style="list-style-type: none"> Mode switch: CLOSE. <ul style="list-style-type: none"> Door closed. Press 4 button keypad down button ▼ for greater than 8 s. <ol style="list-style-type: none"> All parameters reset to factory settings. Procedure completed when "8" on 2 digit displays blinks twice. Installed upgrade cards remain valid and do not require reinstallation. Learning cycle required. <hr/> <p>Extended factory settings.</p> <ol style="list-style-type: none"> Mode switch: CLOSE. <ul style="list-style-type: none"> Door closed. Set SL=2 Press 4 button keypad down button ▼ for greater than 8 s. <ol style="list-style-type: none"> All parameters reset to factory settings. Installed upgrade cards deleted from operator memory. Procedure completed when "8" on 2 digit displays blinks twice. Parameter SL automatically reset to 1. Control unit and upgrade cards can be used independently (delivery status). Learning cycle required..
Opening angle				<ul style="list-style-type: none"> Door opening angle set during learning cycle is displayed. Opening angle can only be changed during learning cycle. Due to installation and parameter tolerances, display value may not match actual door position.
33	 0 - 110	°		
Automatic/manual door closer mode				<p>0=Automatic mode. This mode is applicable whenever door is mainly opened automatically and where motion detectors are installed.</p> <ul style="list-style-type: none"> Mode is optimized for high frequency use. Full energy upgrade card provides for higher door opening and closing speeds. In case door is blocked during a closing cycle, operator reverses automatically. Driving phase is optimized to provide reliable closing cycles. Keep closed force (wind load control) parameter FH and Push & Go function parameter PG are only available in automatic mode. <hr/> <p>1=Manual mode. This mode is applicable whenever door is mainly used manually and only rarely automatically.</p> <ul style="list-style-type: none"> In case door is blocked during a closing cycle, door will stop at its current position. Driving phase optimized for manual opening cycles. Power assist function parameter hf is only available in manual mode.
34	 0 - 1		1	
Power assist activation angle				<ul style="list-style-type: none"> Setting of door activation angle for Power assist function (hF). Higher settings of hA result in better spring force compensation for easier manual opening. Power assist function is more sensitive the smaller the activation angle.
35	 1 - 5	°	3	

Fine cover, Narrow header

Setup and Troubleshooting Instructions









A.1.1 Driving parameters detail.

Parameter	Value range	Units	Factory setting	Description
Power assist function				
36	 0 - 10		0	<ul style="list-style-type: none"> Force setting for Power assist function. Power assist function only available with hd parameter = 1, manual mode. "0"; power assist function OFF. Power assist function enabled for available values greater than 0. Power assist function enabled when power assist activation angle hA reached. The greater the value of hF, the easier the door can be manually opened from power assist activation angle hA. If power assist set too high, door can open automatically. Power assist function is not available If operator is switched off., A smoke detector or emergency button has been triggered.
Additional Power assist function support from 0°				
37	 hS 0 - 99		0	<ul style="list-style-type: none"> Setting for additional power assist function support from 0°. The greater the value of hS, the easier the door can be manually opened from 0°.
A1.1.1 Upgrade card units codes				
	0 - 3		0	<ul style="list-style-type: none"> 0 Upgrade card not installed, function not available. 1 Upgrade card installed, function not activated. 2 Upgrade card installed, function activated. 3 Upgrade card has been removed, function no longer available.
Upgrade card fire protection				
38	 Available upgrade card codes (Para. A1.1.1) 0, 2, 3		0	<ol style="list-style-type: none"> Activate function by installing upgrade card, parameter value will automatically change to 2 (upgrade card function installed, fire protection function activated). <ul style="list-style-type: none"> Following activation, drive may be used as a electrically controlled hold-open system according to EN 14637, Building hardware-Electrically controlled hold-open systems for fire/smoke door assemblies, or similar standards. Full energy function (F2) is automatically activated (ED100/ED250). Plug for terminal board X9 socket included with upgrade card.
Full energy– upgrade card not required to enable function.				
39	 Available upgrade card codes (Para. A1.1.1) 0, 2, 3		0	<p>ED50: low energy only (ANSI/BHMA A156.19).</p> <ul style="list-style-type: none"> F2=0, no parameter adjustment. <p>ED100/ED250</p> <ul style="list-style-type: none"> F2 default is 0, low energy (ANSI/BHMA A156.19). <ol style="list-style-type: none"> To activate Full energy function (ANSI/BHMA A156.10) change parameter F2 to 2. The full setting range of parameters So, Sc, Fo and Fc will be available after the activation. SL (Factory setting level) of 2 will reset F2 to 0.
40			0	Not used.
41			0	Not used.
42			0	Not used.

Fine cover, Narrow header

Setup and Troubleshooting Instructions







A.1.1 Driving parameters detail.

Parameter	Value range	Units	Factory setting	Description
Upgrade card barrier-free toilet				
43		Available upgrade card codes (Para. A1.1.1) 0, 1, 2, 3	0	<ol style="list-style-type: none"> Once upgrade card installed, parameter value will automatically change to 1 (upgrade card installed, function not activated). Activate function by changing parameter F7 to 2. Operator power reset is required; turn power switch off, wait 10 s and turn power back on. <ul style="list-style-type: none"> Upgrade card assigns inputs and outputs of the control unit with functions which are required for this application.
Upgrade card DCW				
44		Available upgrade card codes (Para. A1.1.1) 0, 2, 3	0	<ol style="list-style-type: none"> Activate function by installing upgrade card, parameter value will automatically change to 2. <ul style="list-style-type: none"> Upgrade card provides operator with DCW bus connection. Plug for terminal board X8 socket included with upgrade card. DCW bus enables connection of: <ul style="list-style-type: none"> Program switch EPS DCW (max. 2) Motor lock controls SVP-S 2x DCW (max. 2) Motor lock SVP 2000 (max. 1) RM-ED lintel mounted smoke detector Key switch button ST 32 DCW (max. 2) I/O module DCW (max. 1)
COM 1 configuration interface				
45		0 - 1	0	<ol style="list-style-type: none"> Interface programmed for communication with dormakaba handheld. Interface programmed for use with dormakaba TMS Soft control software.
Backcheck when door opened manually				
46		5 - 40 (v1.9)	°	<ul style="list-style-type: none"> Angle after which door is braked when manually opened. Back check level is automatically optimized during manual door opening cycles. bc function improves door braking behavior in end position so door does not move beyond set opening angle OA <ol style="list-style-type: none"> Entered bc value is subtracted from set opening angle OA, example: <ul style="list-style-type: none"> Opening angle, 90°: Parameter bc, 12°, door back check starts at 78°.
Door thickness				
47		0 - 99	mm	<ol style="list-style-type: none"> Enter parameter Td in mm. <ul style="list-style-type: none"> Door thickness affects measured door opening angle. Parameter Td enables a more accurate door width to be entered, if required.
		0 - 3 7/8"		1 3/8"
Deactivation of drive; X6, 4 and 4a, trigger type				
48		0 - 1	0	<ol style="list-style-type: none"> NC contact, drive function is deactivated when NC contact is open. NO contact, drive function is deactivated when NO contact is closed.
Night-bank contact X1; 3 and 35, trigger type				
49		0 - 1	0	<ol style="list-style-type: none"> NO contact, night-bank function is triggered when NO contact is closed. <ul style="list-style-type: none"> Typically used when using a key switch or an access control system. NC contact, night-bank function is triggered when NC contact is opened. <ul style="list-style-type: none"> Typically used when connected to building management system to trigger doors (signal normally present).

Fine cover, Narrow header

Setup and Troubleshooting Instructions

A.1.1 Driving parameters detail.

Parameter	Value range	Units	Factory setting	Description
Release of hold-open system				
50	 0 - 1		1	<p>1 Upgrade care Fire Protection installed.</p> <p>2 Set parameter FC to 1. Users may release hold-open by manually moving door in closed direction.</p> <ul style="list-style-type: none"> A manual release button is not required. <p>0</p> <ul style="list-style-type: none"> Hold-open release by manually moving door in closed direction is deactivated. A manual release button is required.
Castor angle for double doors				
51	 0 - 30	°	30	Primary door with astragal, angle active door must open before secondary door opens.
Hinge clearance				
52		± 5 *10 mm $\pm 3/16$ *10 inches	3 *10	<ul style="list-style-type: none"> Clearance between hinges is critical for the calculated door angle. HS parameter may only have a small effect but the hinge clearance can be adjusted in extreme cases to improve accuracy. Factory setting is 3 * 10, 30 mm, 1 3/16". With CPD doors, setting must be changed to a negative value. A learning cycle is then required as system creates an angle table as a function of the set parameters.
Overhead concealed mode (OHC): Activation of permanent open via night-bank input				
53	 0 - 1		0	<p>0 Function disabled.</p> <p>1 If night-bank signal is longer than 3 seconds, operator changes to permanent open mode.</p>
Overhead concealed mode (OHC): Adjustable behavior after blockage / hold open				
54	 0 - 1		0	<p>0 Standard behavior (3 x restart).</p> <p>1 Manual mode after blockage.</p>
Reversing after trigger of approach side safety sensor / opposite hinge side in operating mode hd=1				
55	 0 - 1		0	<p>0 Standard behavior, stop.</p> <p>1 Reversing</p>

Appendix B - Troubleshooting

B.1 Information and error codes

- 1 4 button keypad
- 2 2 digit display

Fig. B.1.1 User interface

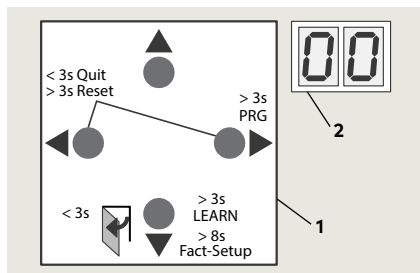

- 3 Power switch
- 4 Red LED
- 5 Yellow LED
- 6 Green LED

Fig. B.1.2 Operator LEDs

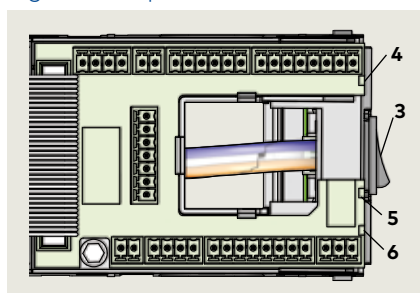
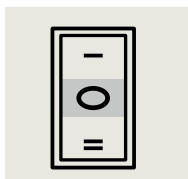

Fig. B.1.3 Mode switch

- 7 Mode switch, Close position



TIPS AND RECOMMENDATIONS

Para. B.3, Information codes
 Para. B.4, Error codes

B.1.1 Overview

Operator monitors internal circuits and external safety circuits managed by the operator.

B.1.2 Error and information messages.

1. With operator in use, certain conditions may develop resulting in error or information messages.
2. Operator attempts to identify the cause and respond accordingly.
3. Response depends on the severity of the error:
 - Information message (**In**)
 - Error message (**E**)
 - Deactivating the operator's automatic function; operator will switch to emergency mode. Users can then access door manually.

B.1.3 User information display.

User interface display, or dormakaba handheld displays:

- Information **In** codes
- Error message **E** codes

B.1.4 Viewing error messages.

To access and view error messages, briefly press the right button on the 4 button keypad.

B.1.5 Red LED on operator .

Red LED adjacent to operator power switch displays blinking codes for:

- Certain **In** information
- **E** error codes (Para. B.2)

B.1.6 Resetting error codes.

Options for resetting error codes:

1. Set Mode switch in Close (off) position.
2. User interface Reset buttons:
 - Press both left and right buttons >3s to reset system (v1.8).
 - Header cover must be opened to access user interface.
3. Power reset:
 - Turn power switch OFF.
 - Turn power switch back on after 10 seconds.

CAUTION

Always analyze and remove cause for error before resetting error message!
 Troubleshooting charts (Para. B.3,4) are intended as a guide for diagnosing errors.

Fine cover, Narrow header**Setup and Troubleshooting Instructions****B.1.7 Error message memory.**

1. There are ten error message memory locations; E 0 through E 9.
2. The latest error message is always stored in error memory location E 0:
 - As soon as another error occurs, the existing error stored in E 0 will be moved to E 1 and the latest error will be stored in E 0.
3. A maximum of 9 errors can be stored in memory locations E1 through E9.
4. Identical error messages occurring one after another are not stored again.

B.2 Red LED status codes

Table B.2.1 Red LED status codes

Red LED status	Display	Description
Steady flashing		Control unit has detected error, emergency mode activated.
On steady	In 11	Hold-open device triggered.
Flashing 2 times	E 02	Locking device error.
Flashing 4 times	E 04	Safety sensor test error.
Flashing 5 times	E 25	SVP PR DCW module test negative.
	E26	ED50 braking error.
Flashing 5 times	E 51 E 52 E 53	Incremental encoder error.
Flashing 6 times	E 62	Double door operation, 2nd system has incompatible firmware version.
Flashing 6 times	E 63	Double door operation, 2nd system has incompatible fire protection setting.
Flashing 7 times	E 71	System error 1 (test), second shutdown option.
Flashing 7 times	E 72	System error 2 (test), current measuring circuit.
Flashing 7 times	E 73	System error 3 (test), braking circuit
Flashing 12 times	E 12	EEPROM error
Flashing 13 times	E 13	Motor overcurrent
Flashing 15 times	E 15	Faulty learning cycle

Fine cover, Narrow header

Setup and Troubleshooting Instructions

B.3 Troubleshooting chart, "In" codes

B.3.1 Troubleshooting chart, information messages.

No.	Display	Red LED	Description	Troubleshooting information messages
	In 01	Off	<p>Obstruction Door obstructed by an obstacle or person; door movement stopped by operator.</p>	<p>Sustained operation on a door with an obstruction can result in damage to drive.</p> <ol style="list-style-type: none"> Object or person obstructing door movement. <ul style="list-style-type: none"> Check door movement while system is deenergized. Remove cause of anything obstructing door movement. Sensor detection range too small. <ul style="list-style-type: none"> Obstructions are often caused by people using door due to sensor's detection range not matching operator's opening speed. Door is unavoidably contacted by person using door. Sensors detection range should be increased and/or operator's opening speed should be increased. Test system operation after cause of obstruction found.
2	In 08	Off	<p>Deactivation of drive function.</p> <ul style="list-style-type: none"> Contact at X6, 4 and 4a is opened. Operator switched to emergency mode, door can only be used manually. 	<p>An emergency close switch, lock switch, or other system safety device may be connected to the X6 input.</p> <ul style="list-style-type: none"> One of the activators connected to X6 may have opened, or a defect is present. <ol style="list-style-type: none"> Reset the applicable activator. Operator should start operation automatically. If In 08 still present, check activators or system wiring.
3	In 09	Off	<p>Upgrade card error.</p> <ul style="list-style-type: none"> Installed upgrade card has been removed. If two upgrade cards were installed, the upgrade card installed first (container module) has not been reinstalled or is defective. 	<ol style="list-style-type: none"> Installed upgrade card cannot be removed. <ul style="list-style-type: none"> If more than one upgrade card is installed, the first card installed becomes the container module. The container module must be installed last, after all other Upgrade cards are installed. If container module is defective, first upgrade card (container module) must be replaced and all other upgrade cards must be reinstalled.
4	In 11	On	<p>Hold-open system triggered.</p>	<ol style="list-style-type: none"> Hold-open system can be triggered: <ul style="list-style-type: none"> Automatically by smoke detector or building interface system. Manually by a manual release button. Manually moving door. The system must be reactivated by a deliberate action. Depending on system's configuration, reactivation can be done by: <ul style="list-style-type: none"> Manually moving door to taught opening angle. Switching program switch to Close (off). Pressing both 4 button keypad left ◀ and right ▶ buttons greater than 3s. It must be ensured that a smoke detector or building interface has not been triggered. If reactivation is unsuccessful, there may be a defect in the smoke detector or building interface system or its connections.
5	In 23	Off	<p>Locking alarm.</p> <ul style="list-style-type: none"> Door is blocked while in the closed position. 	<ul style="list-style-type: none"> Most common cause of this error is the drive unit attempting to open a locked door. <ol style="list-style-type: none"> To eliminate the occurrence of this error, install a lock status switch. <ul style="list-style-type: none"> Lock switch detects the lock pin's switching status and switches the drive unit off if necessary. It is recommended to use a lock status switch, as repeated attempts to open a locked door may damage the drive unit or the door.

Fine cover, Narrow header

Setup and Troubleshooting Instructions

B.3.1 Troubleshooting chart, information messages.

No.	Display	Red LED	Description	Troubleshooting information messages
6	In 61	Off	Communication error, double door system. <ul style="list-style-type: none"> No communication between the two operators. 	<ol style="list-style-type: none"> Check communication cable connection at the two operators. Cable connects to the horizontal RJ 45 connector next to the user interface. Check communication cable.
7	In 72	Off	Current measuring circuit. <ul style="list-style-type: none"> System could not successfully perform internal current measuring test, performed once every 24 hours. 	<ul style="list-style-type: none"> The initial current measuring test may not always be successfully completed due to system tolerances and environmental conditions. The test may also fail, as an example, if someone uses the door while the test is in progress.
8	In 73	Off	Braking circuit test. <ul style="list-style-type: none"> System could not successfully perform internal braking circuit test, performed once every 24 hours. 	<ul style="list-style-type: none"> The initial braking circuit test may not always be successfully completed due to system tolerances and environmental conditions. The test also may fail, as an example, if someone uses the door manually while the test is in progress. If the cyclical test fails ten times in a row, error message In 73 will be displayed.
9	In 91	Off	DCW communication. <ul style="list-style-type: none"> At least one registered DCW device is missing. 	<ol style="list-style-type: none"> Reconnect the corresponding DCW device. If this is not possible, reactivate the drive. Reactivation can be done by: <ul style="list-style-type: none"> Switching program switch to Close (off). Pressing both 4 button keypad left ◀ and right ▶ buttons greater than 3s.

B.4 Troubleshooting chart, "E" codes

B.4.1 Troubleshooting chart, "E" codes.

No.	Display	Red LED	Description	Troubleshooting error codes
1	E 02	Flashing 2 x	Locking device error. <ul style="list-style-type: none"> Operator is attempting to open or close a locking device with feedback, or a DCW locking device. An error has occurred during this process. 	<ul style="list-style-type: none"> Probable causes are a defective locking device or wiring defect. 1. Check the locking device and feedback system.
2	E 03	Flashing 3 x	DCW program switch is missing.	<ol style="list-style-type: none"> Check the DCW program switch and its connections.
3	E 04	Flashing 4 x	Safety sensor test error. <ul style="list-style-type: none"> Test of moving safety sensors was unsuccessful. 	<ul style="list-style-type: none"> Factory setting level of "safety sensor test" parameter ST is 0, test off (Appendix A, Parameter detail). When ST is configured to installed safety sensors, a test signal is sent to the sensors before each door opening or closing cycle. Operator waits for a response within a certain time window. Check whether parameter ST has been configured to the installed safety sensors and their active-high or active-low signal level. Check for activation of the test at the safety sensors.

Fine cover, Narrow header

Setup and Troubleshooting Instructions

B.4.1 Troubleshooting chart, "E" codes.

No.	Display	Red LED	Description	Troubleshooting error codes
4	E 12	Flashing 12 x	<p>EEPROM error.</p> <ul style="list-style-type: none"> Internal memory check could not be completed. Drive unit works in door closer mode. 	<ul style="list-style-type: none"> Using dormakaba handheld, reload current firmware to reinitialize system. If the error is still present, the control unit must be replaced.
5	E 13	Flashing 13 x	<p>Overcurrent detection. Motor is consuming more current than drive unit can provide.</p>	<ul style="list-style-type: none"> Motor is consuming too much power, check for any external causes. Drive unit or control unit is defective. If error repeats, operator must be replaced.
6	E 15	Flashing 15 x	<p>Faulty learning cycle. Learning cycle could not be completed (Chapter 10).</p>	<ul style="list-style-type: none"> Error may occur if learning cycle has been interrupted, for example if door movement has been interrupted during the learning cycle. Learning cycle must be repeated.
7	E 25	Flashing 5 x	<p>SVP-PR 12 power reserve module test negative.</p>	<ul style="list-style-type: none"> See Appendix A, parameter TS, Power reserve module test. Check power reserve module and its wiring.
8	E 26		<p>ED50 brake error.</p>	<p>Reference applicable ED50/ED100/ED250 Installation Manual, Maintenance, Brake maintenance.</p> <ol style="list-style-type: none"> Brake error during learning cycle. <ul style="list-style-type: none"> Check brake wire connections on X3 terminal strip. Verify wire insulation has been properly stripped from end of wires and wires are secured under terminals. Red wire terminated on 1G, black wire on 3. Reference brake wiring figure. Verify that the only wiring on X3 terminals 1G and 3 are the brake wires. Brake air gap tolerance issue. <ul style="list-style-type: none"> Brake air gap adjustment. Reference adjustment of air gap. <p>Brake power (1G: +27 Vdc, 3: 0V).</p> <ul style="list-style-type: none"> ON when door is in fully opened position. OFF when hold-open time expires.
9	E 51 E 52 E 53	Flashing 5 x	<p>Incremental encoder error.</p> <ul style="list-style-type: none"> Motor gear unit encoder monitoring detected a faulty state. 	<ol style="list-style-type: none"> Check encoder plug connection at operator. <ul style="list-style-type: none"> Secure connection. Wiring terminations Short circuits. Check locking device for short circuits. <ul style="list-style-type: none"> Error can be caused by defective motor or short circuit in locking device. Motor gear unit must be replaced in event of defective motor.
10	E 62	Flashing 6 x	<p>Incompatible firmware version, double door system, second system.</p>	<ul style="list-style-type: none"> Equip both operators with same firmware version.

Fine cover, Narrow header

Setup and Troubleshooting Instructions

B.4.1 Troubleshooting chart, "E" codes.

No.	Display	Red LED	Description	Troubleshooting error codes
11	E 63	Flashing 6 x	Incompatible fire protection setting. double door system.	<ul style="list-style-type: none"> For double door systems, the Upgrade card fire protection must be installed in both control units.
12	E 71	Flashing 7 x	System error 1, 2nd shutdown option.	<ul style="list-style-type: none"> In order to reliably switch off the drive unit, several switching elements are used and their functions are tested periodically. If the function test always results in the error code, the control unit must be replaced.
13	E 72	Flashing 7 x	System error 2, current measurement circuit.	<ul style="list-style-type: none"> The current measurement circuit is part of the safety mechanisms and its function is tested periodically. If the function test always results in the error code, the control unit must be replaced.
14	E 73	Flashing 7 x	System error 3, braking circuit.	<ul style="list-style-type: none"> The braking circuit is a safety element in the closer mode and will be tested every 24 hours. During the test the motor is shut down during door closing and the door closes at a set angle in emergency mode. Test can be noticed as a short jerk on the door and is normal. Error can be due to door closing in the deenergized state too fast (under 3 seconds). See Chapter 9, Power fail closing speed. <ol style="list-style-type: none"> 1. Check the closing speed and reduce if necessary.
15	PF		Short circuit of 24 V supply voltage.	<ol style="list-style-type: none"> 1. Eliminate short circuit.
16	- 1 - 2 - 3 - 4		Energy management. <ul style="list-style-type: none"> Motor is too hot (for example, too high an ambient temperature) System responds automatically. 	<ol style="list-style-type: none"> 1. Movement dynamics in the closed direction will be reduced. 2. Movement dynamics in both the open and closed directions will be reduced. 3. System shuts down for 3 minutes (door closer mode). 4. Hold-open time will be extended.

Appendix C - dormakaba handheld

C.1 dormakaba handheld terminal

Fig. C.1.1 dormakaba handheld

- 1 Off/On key
- 2 Function keys
- 3 Arrow keys
- 4 ENTER key
- 5 DEL key
- 6 SHIFT key
- 7 Alpha numeric keyboard
- 8 LED, recharging battery status (Off when batteries fully charged)
- 9 SD card slot

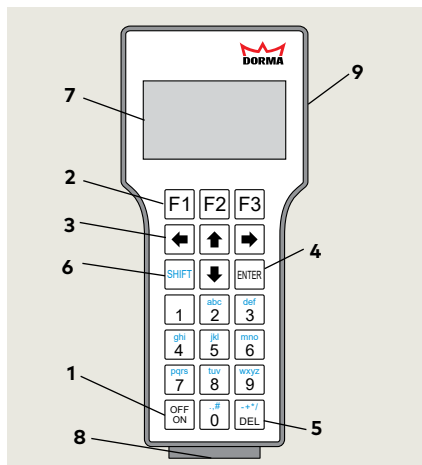

C.1.1 Interface cable

Use dormakaba interface cable (Article No. 16596101170) to connect dormakaba handheld to operator Com 1 interface.

CAUTION

Never use conventional network cable with RJ45 plug! Using conventional cable may result in permanent damage to operator!

Fig. C.1.2 Com 1 interface

- 1 2 digit display
- 2 4 button keypad
- 3 Com 1 interface

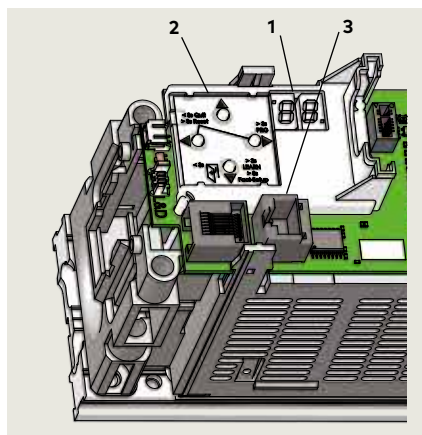

C.1.2 Handheld key functions.

1. OFF ON, switches Handheld on or off.
2. Function keys F1 - F3, trigger functions shown in bottom line of display (e.g., "RPT" for repeat, "UP" and "DOWN" to switch lines, "UpDoLd" for file up and download, "CHANGE" to change values, "OPEN" to trigger opening pulses).
3. Arrow keys, allow navigation within the display. Use left arrow to get back to previous screen.
4. ENTER, selects individual menu items and confirms changes of values and settings.
5. DEL, deletes figures or letters.
6. SHIFT, switch between figures and letters or small and capital letters. Current function is indicated on display (n: numeral, A: capital letters, a: small letters).
7. Alpha numeric keyboard, allows entering values and file names in small and capital letters. There are several special characters (dot, comma, hash key, plus, minus, asterisk and diagonal slash).

C.1.3 Handheld startup.

1. Press OFF ON to turn on Handheld terminal.
2. Screen displays Current version, creation date and name of data base. Handheld is ready for operation.
3. Select "COMMUNICATION" and enter user code (dormakaba original setting: 123456).
4. Handheld displays current software version of the connected operator (e.g., Ed100 SW- V2.3.0).

C.1.4 Downloading current parameters.

1. Press function key F2 "UpDoLd" to access menu "UP/DOWNLOAD".
2. Select "Download" to download current adjustments and parameters. System stores this data as temporary file under file name "temp.tab".
3. Every change in configuration, parameter setting or special functions confirmed with the "ENTER" key automatically uploads to the operator.
4. The Handheld does **not** automatically save the changes. The Handheld will prompt you to save the changes when quitting the menu.

C.1.5 Menu structure

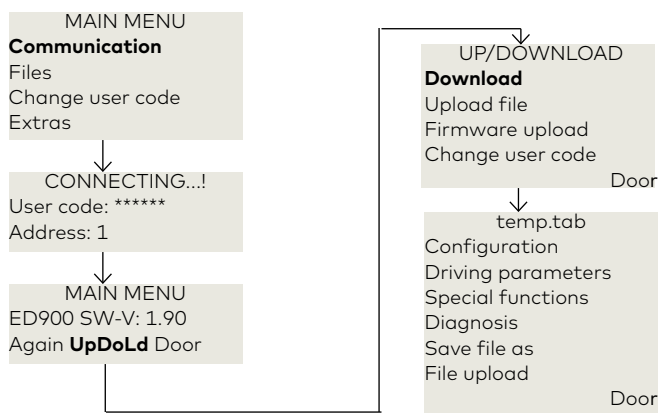

Fine cover, Narrow header

Setup and Troubleshooting Instructions

C.2 New dormakaba handheld; language change to English

Fig. C.2.1
dormakaba handheld

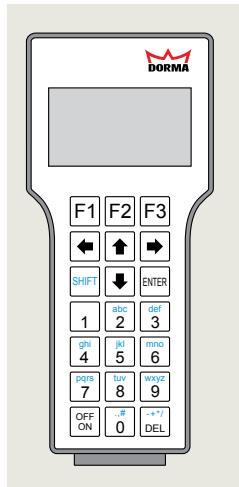

C.2.1 New dormakaba handheld; language change.

If German language is displayed on screen when handheld is first turned on (Fig. C.6.2, handheld power on sequence), use following steps to change to English.

Fig. C.2.2 HAUPTMENUE (main menu)

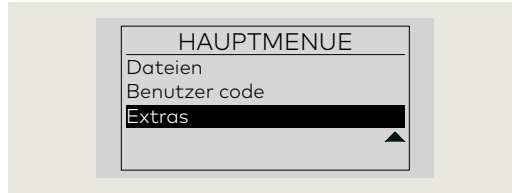

1. Scroll down Main Menu to EXTRAS:
 - Press 3 times to highlight EXTRA.

Fig. C.2.3 Main Menu; EXTRAS highlighted.

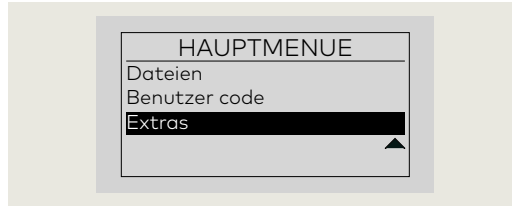

2. Press to select EXTRAS menu.

Fig. C.2.4 EXTRAS menu

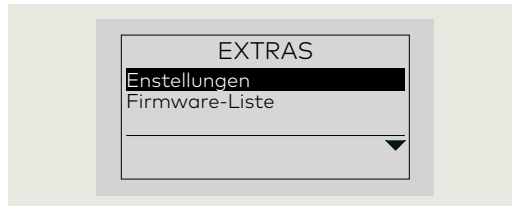

3. Press to select EINSTELLUNGEN (Settings) menu.

Fig. C.2.5 EINSTELLUNGEN menu

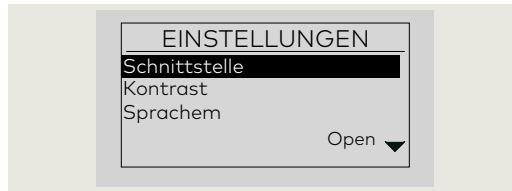

4. Scroll down EINSTELLUNGEN Menu to Sprachen (Languages):
 - Press twice to highlight Sprachen.

Fig. C.2.6 Sprachen highlighted



5. Press to select Sprachen (Fig. C.2.8).

Fig. C.2.7 Sprachauswahl (Language Selection) menu

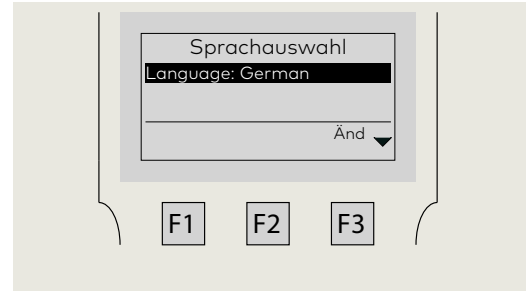

6. Press to select Änd (Amendments).

Fig. C.2.8 SPRACHEN menu

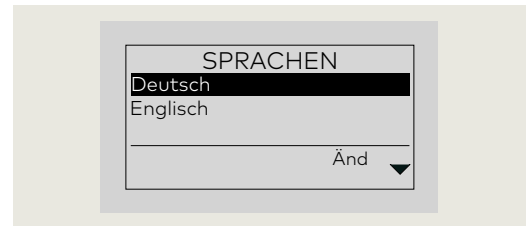

7. Scroll down SPRACHEN menu to English: Press once to highlight "English"

Fig. C.2.9 Englisch highlighted

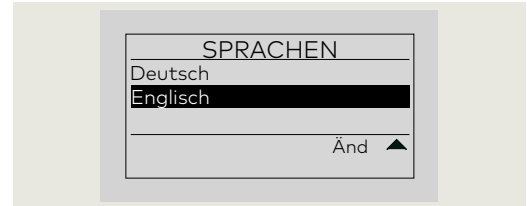

8. Press to select English.

Fig. C.2.10 SETTINGS menu

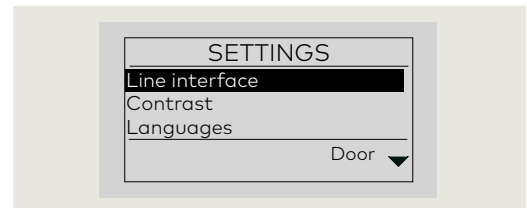

TIPS AND RECOMMENDATIONS

Handheld programmer will retain English setting when unit is turned off. Change to English only required the first time the programmer is turned on "out of the box".

C.3 dormakaba handheld; firmware update

C.3.1 Firmware update procedure

CAUTION

For all firmware changes, set program switch to CLOSE and allow door to close completely before any updates are made!

Fig. C.3.1 Handheld power on sequence

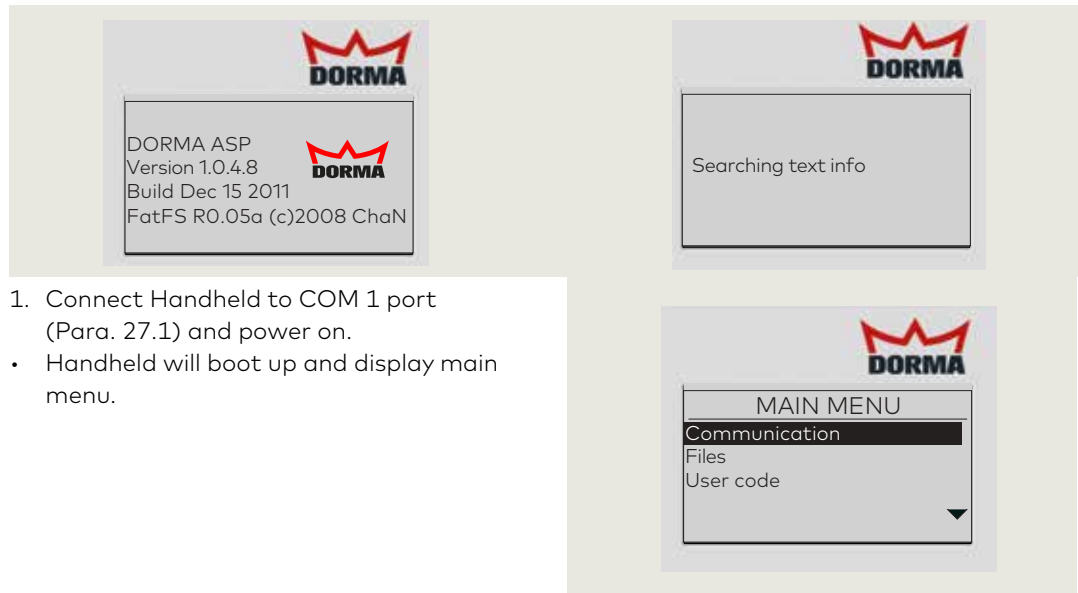

1. Connect Handheld to COM 1 port (Para. 27.1) and power on.
- Handheld will boot up and display main menu.

Fig. C.3.2 Select communication menu

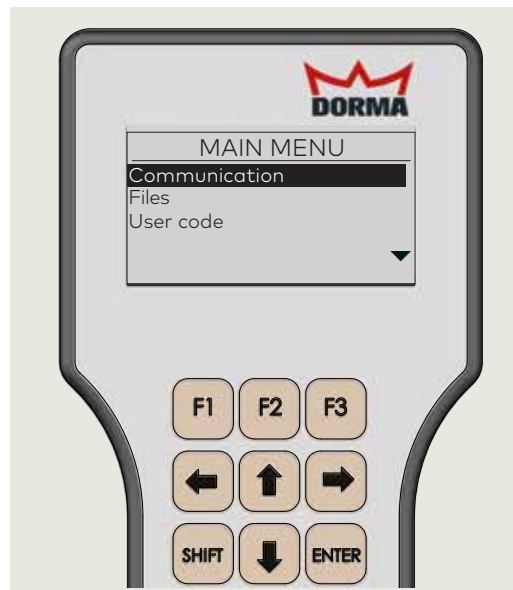

2. With Communication highlighted, press ENTER.

Fig. C.3.3 Enter Handheld user code

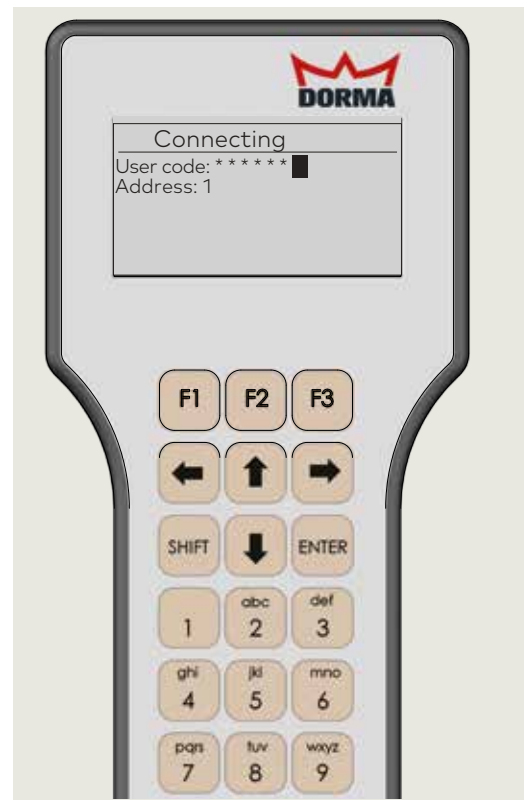

3. Enter handheld user code and press ENTER.

1 ENTER button

Fine cover, Narrow header

Setup and Troubleshooting Instructions

- 1 ENTER button
- 2 F2 button
- 3 Up/down arrows

Fig. C.3.4 Select UpDoLd

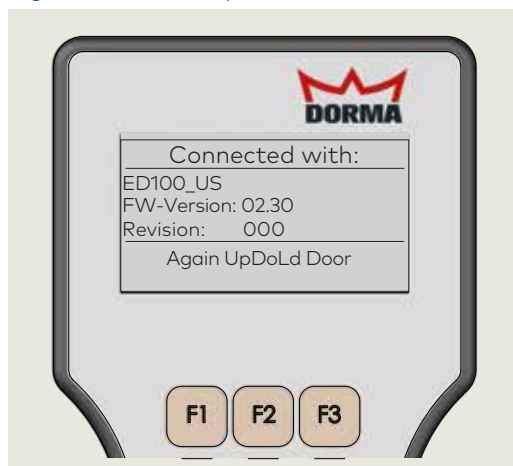

4. Press F2 to select UpDoLd.

Fig. C.3.5 Select Firmware upload

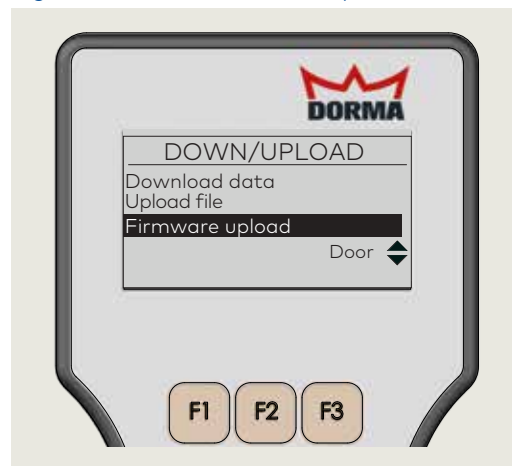

5. Use Up and Down arrows to select Firmware upload and press ENTER.

Fig. C.3.6 Select Firmware version

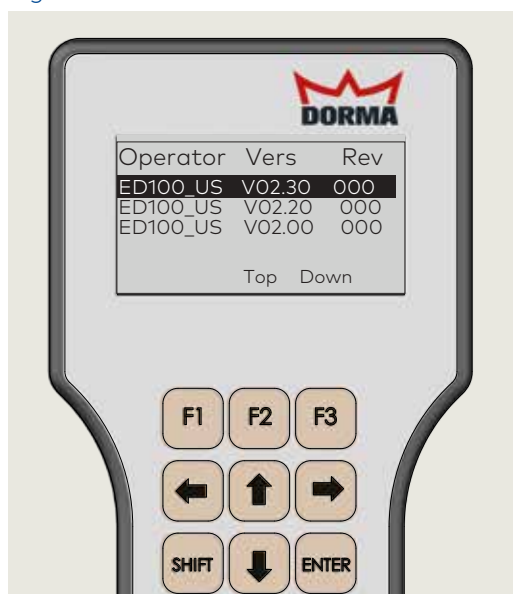

6. Use Up and Down arrows to select firmware version and press ENTER.

Fig. C.3.7 Start transmission

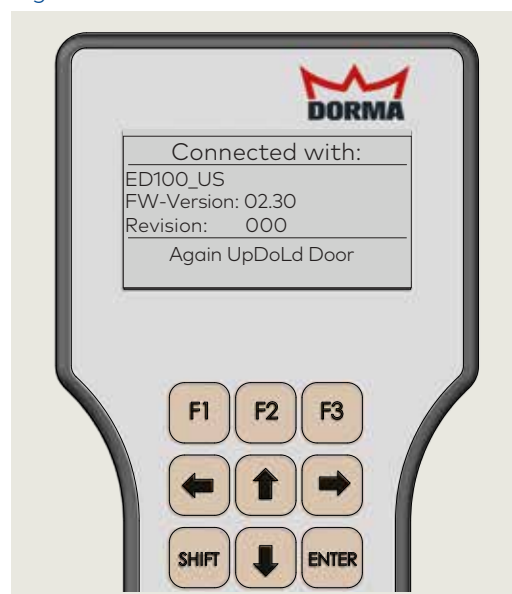

7. Press any key to start firmware transmission.

Fig. C.3.8 Firmware uploading

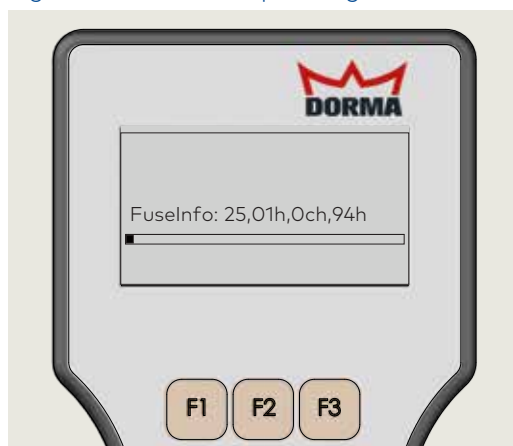

8. Firmware uploading to controller. Wait time of 3 to 5 minutes to upload.

Fig. C.3.9 Complete firmware update

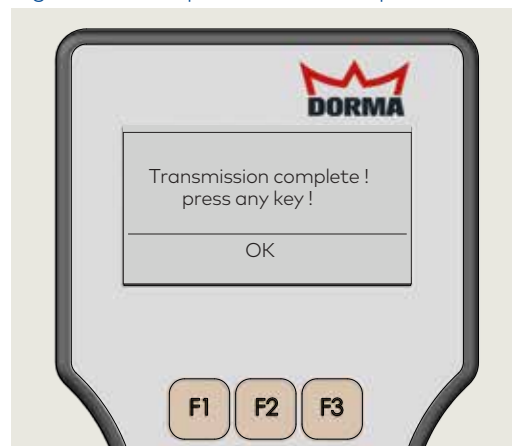

9. Press any key to complete firmware update.

