

# ED50/ED100/ED250

## Swing Door Operators

### Owner's Manual

DL4616-006 – 09-2021

| EN |

dormakaba 

# Table of contents

<b>Table of contents</b>	<b>2</b>
<b>1 General information</b>	<b>3</b>
<b>2 To our customers</b>	<b>4</b>
<b>3 What you should know</b>	<b>5</b>
3.1 Distributor information	5
3.2 ED50 low energy operator	5
3.3 ED100/ED250 power configuration	5
3.4 Low energy power operated swinging doors ANSI/BHMA A156.19	5
3.5 Power operated swinging doors ANSI/BHMA A156.10	5
3.6 Mode switch and Exit Only switch panels	6
<b>4 AAADM Safety information labels</b>	<b>7</b>
4.1 Safety information label, automatic swinging doors	7
4.2 Safety information label, low energy swinging doors	7
<b>5 Daily safety check procedure</b>	<b>8</b>
5.1 Power operated swing doors (ANSI/BHMA A156.10)	8
5.2 Low energy power operated swing doors (ANSI/BHMA A156.19)	9
<b>6 General safety related items</b>	<b>10</b>
6.1 Power operated swing doors (ANSI/BHMA A156.10)	10
6.2 Low energy power operated swing doors (ANSI/BHMA A156.19)	11
<b>7 ED50/ED100/ED250 door signage</b>	<b>12</b>
7.1 ED100/ED250 operator configured as full energy	12
7.2 ED50 operator and ED100/ED250 operator configured as low energy	12
7.3 Door signage, full energy single swing door	13
7.4 Door signage, low energy swing door	13
7.5 Door signage, full energy double door	14
7.6 Door signage, full energy double egress door	15
7.7 Door signage, low energy double doors	16
<b>8 ED50/ED100/ED250 maintenance</b>	<b>17</b>
8.1 ED50/ED100/ED250 environment and maintenance	17
8.2 ED Operator status LEDs	17

# 1 General information

## 1.1 Owner's Manual

This Owner's manual applies to dormakaba ED50/ED100/ED250 swing door operators supplied with a fine cover.

## 1.2 ED50/ED100/ED250 with fine cover installation.

### NOTICE

#### Interior building surface installation.

The ED50/ED100/ED250 with fine cover must be installed on an interior building surface.

#### Exterior door use.

To insure proper suitability for exterior door use, the following topics must be addressed in the context of the door application setting.

- Site-specific use factors such as high wind conditions and/or building pressure.
- Door width, height, weight, and usage patterns.
- Observable prevailing conditions at the opening under which the operator is expected to perform. In some instances, this may require increased force settings to counteract these conditions.
- Door mounted presence sensors. When attempting to overcome these forces, it is strongly suggested that door mounted presence sensors be employed to enhance pedestrian safety through the opening.

Fig.1.1 ED50/ED100/ED250 with fine cover

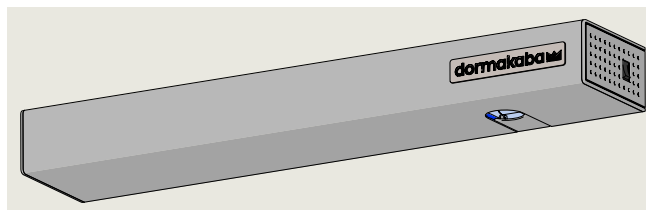

## 1.3 Manual storage.

This document must be kept in a secure place, and accessible for reference as required.

If the door system should be transferred to another facility, insure that this document is transferred as well.

## 1.4 dormakaba.us website.

Manuals are available for review, download, and printing on dormakaba.us website.

## 1.5 Dimensions

Unless otherwise specified, all dimensions are given in inches (").

## 1.6 Symbols used in this manual.



### WARNING

This symbol warns of hazards which could result in personal injury or threat to health.

### NOTICE

Draws attention to important information presented in this document.

## 2 To our customers

We are pleased that a dormakaba ED50/ED100/ED250 swing door system has been selected for this installation. dormakaba designed, tested and built the system to provide many years of service.

The purpose of this manual is to familiarize you with your ED50/ED100/ED250 swing door system.

It is essential that you "know your system" and that you recognize the importance of maintaining your door system in compliance with industry standards for safety.

**It is your responsibility** as owner and caretaker of the equipment, to inspect the operation of your door system on a daily basis as outlined in Chapter 4, Safety information checklist to insure that it is safe for use by your customers and employees.



### WARNING

Should the door fail to operate as prescribed in the Safety information checklist or at any other time for any reason, do not attempt to repair or adjust the ED50/ED100/ED250 swing door system!

Call your local authorized dormakaba USA, Inc. distributor for repair. The distributor's AAADM certified technicians are trained to service the ED50/ED100/ED250 swing door system using the dormakaba USA, Inc. Installation and Setup and Troubleshooting Instructions, and in accordance with ANSI/BHMA safety standards.

### 2.1 Service availability.

dormakaba USA, Inc. has a nationwide network of authorized distributors for sales, installation and service of its products.

### 2.2 Compliance with industry standards for safety.

Your ED50/ED100/ED250 swing door system was designed to the latest ANSI/BHMA operating and safety standards. In order to insure the continued safe operation of the door, it is important that:

- Proper decals and labels be applied and maintained on your doors (Chapter 7).
- If decals and labels have been removed, or cannot be read, contact your local authorized dormakaba USA, Inc. distributor for replacement decals or labels.

## 3 What you should know

### 3.1 Distributor information

#### 3.1.1 dormakaba USA, Inc. distributor information.

Be sure that the dormakaba USA, Inc. distributor has provided the following information for each door installation:

1. dormakaba ED50/ED100/ED250 Owner's Manual DL6116-006.
2. Review of the daily Safety information checklist (Chapter 4).
3. Instructions on how to conduct the daily Safety Information checklist by walk through example.
4. Annual compliance inspection label completion (Chapter 4).
5. Circuit breaker or disconnect location for 115 Vac power to the ED50/ED100/ED250.
6. ED50/ED100/ED250 mode switch panel location and instructions in its use. (Para. 3.6).
7. Discussion of problems that could result from operator being allowed to operate after a malfunction observed.
8. Number to call for service or questions about your system if you are uncertain of any condition or situation.



#### **WARNING**

If there are any problems, discontinue door operation immediately and secure the door in a safe manner.

Call your local dormakaba USA, Inc. distributor for repair.

### 3.2 ED50 low energy operator

ED50 operator is available only as a low energy operator (Para. 3.4).

### 3.3 ED100/ED250 power configuration

ED100 and ED250 operators can be configured for:

- Low energy power operated door (Para. 3.4).
- Power operated (full energy) door (Para. 3.5).

### 3.4 Low energy power operated swinging doors ANSI/BHMA A156.19

#### 3.4.1 Low energy power operator door definition (ANSI/BHMA A156.19).

A door with a power mechanism that opens the door upon receipt of a knowing act signal (Para. 3.4), does not generate more kinetic energy than specified in the ANSI / BHMA A156.19 standard, and is closed by a power mechanism or other means.

#### 3.4.2 Knowing act definition (ANSI/BHMA A159.19).

Any conscious action with the expected result of opening a door. This includes but is not limited to:

- Wall or jamb mounted contact or non contact switches such as pushplates.
- The action of manually opening (pushing or pulling) a door.
- Controlled access devices such as keypads, card readers, wireless transmitters and key switches.

### 3.5 Power operated swinging doors ANSI/BHMA A156.10

#### 3.5.1 Power operated door definition (ANSI/BHMA A156.10).

The combination of door, operator, controls and sensors constituting the system. (Also called automatic door.)

## 3.6 Mode switch and Exit Only switch panel

Fig. 3.6.1 ED operator fine cover

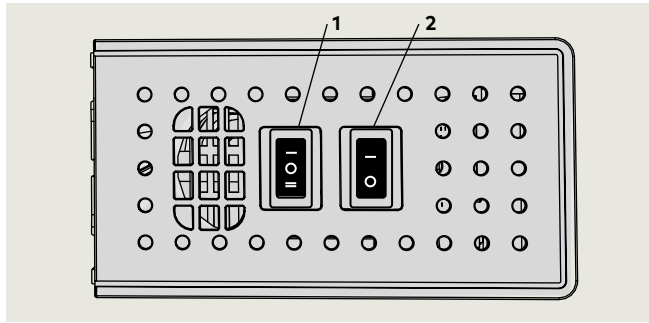

- 1 Mode switch, 3 position  
 2 Exit Only switch, 2 position

Fig. 3.6.7 Optional key switch panels

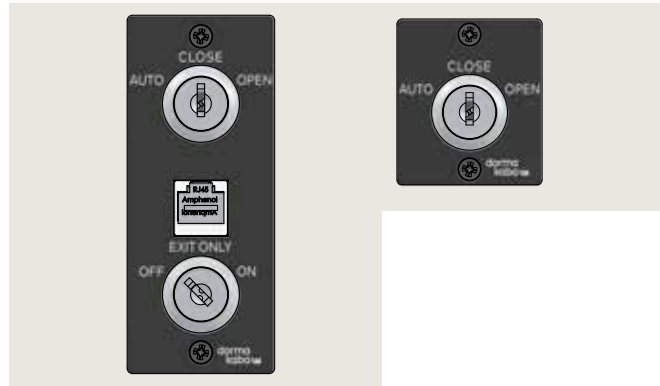

### 3.6.1 Mode switch positions.

Fig. 3.6.2 Auto

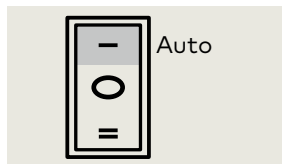

Fig. 3.6.3 Close

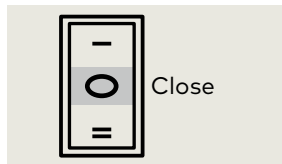
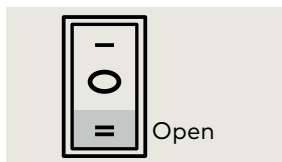

Fig. 3.6.4 Open



### 3.6.2 Exit Only switch positions.

Fig. 3.6.5 On

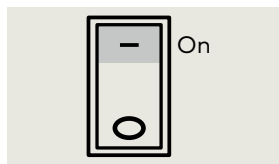
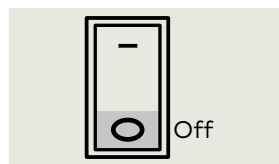

Fig. 3.6.6 Off



### 3.6.3 Mode switch position descriptions.

#### Auto

1. Door opens automatically when one of the activators is actuated or triggered. Door closes on expiration of adjustable hold open time with no activators or actuators triggered.
2. With knowing act device actuation (Para. 3.4.2). Door will remain at full open position for not less than 5 seconds.
3. With push/pull actuation of door (Para. 7.2.4). Door will remain at full open position for not less than 3 seconds.

#### Close

1. Door will remain closed, or if door is open door will close.

#### Open

1. Door opens automatically and remains open.

### 3.6.4 Exit Only switch position descriptions.

#### On

1. Exterior activation sensor or knowing act device disabled when door fully closed.
  - Only interior activation sensor or knowing act device will enable door opening.

#### Off

1. Both interior and exterior activation sensors or knowing act devices will enable door opening.

# 4 AAADM Safety information labels

## 4.1 Safety information label, automatic swinging doors

### 4.1.1 Automatic swinging door safety information label.

This AAADM label outlines safety checks that should be performed daily on automatic swinging door controlled by an ED100/ED250 operator configured for full energy.

### 4.1.2 Safety information label location.

Place label in a protected, visible location on door frame, near operator power switch if possible.

### 4.1.3 Annual compliance section of label.

This section of label is only completed on automatic swing doors that comply with ANSI/BHMA A156.10 standard and pass inspection by a AAADM certified dormakaba USA, Inc. technician.

### 4.1.4 Additional annual compliance inspection labels.

Place additional labels over annual compliance inspection section of safety information label.

## 4.2 Safety information label, low energy swinging doors

### 4.2.1 Low energy swinging door safety information label.

This AAADM label outlines safety checks that should be performed daily on low energy swinging door controlled by an ED50 operator or an ED100/ED250 operator configured for low energy.

### 4.2.2 Safety information label location.

Place label in a protected, visible location on door frame, near operator power switch if possible.

### 4.2.3 Annual compliance section of label.

This section of label is only completed on low energy swing doors that comply with ANSI/BHMA A156.19 standard and pass inspection by a AAADM certified dormakaba USA, Inc. technician.

### 4.2.4 Additional annual compliance inspection labels.

Place additional labels over annual compliance inspection section of safety information label.

Fig. 4.1.1 Safety information labels

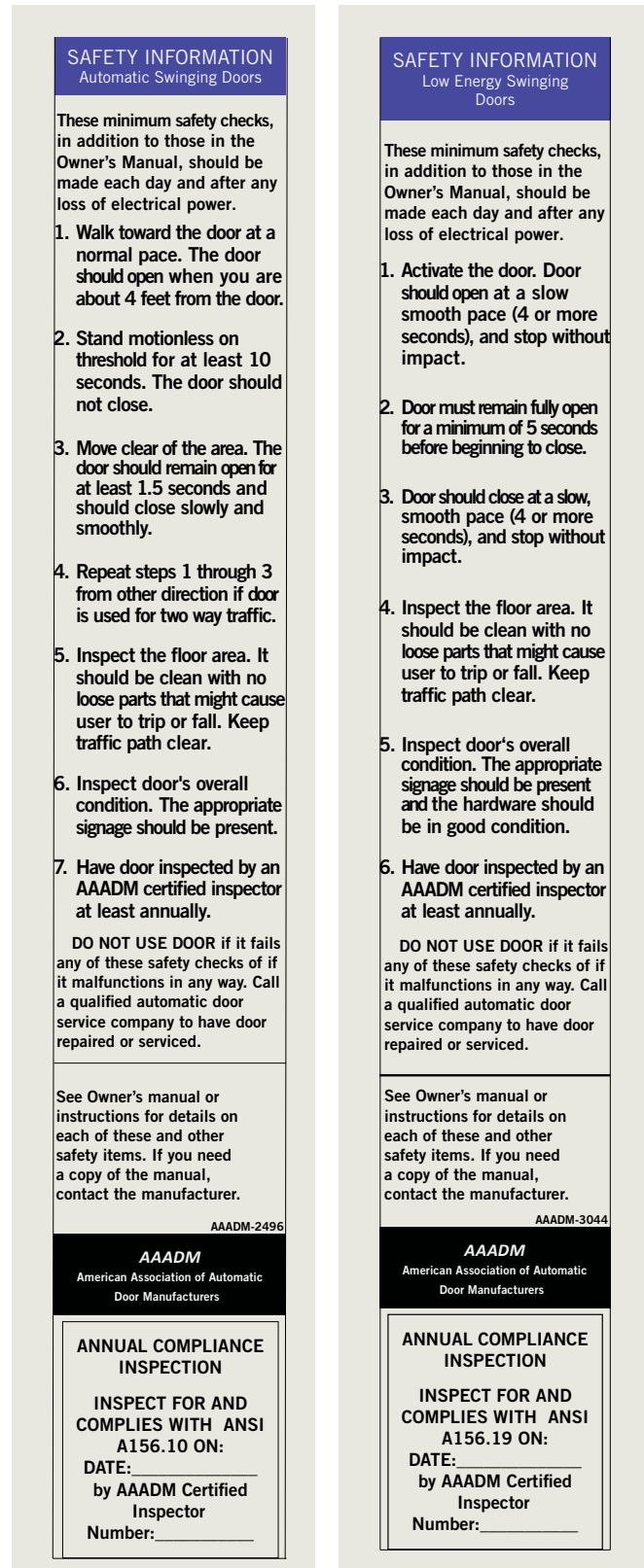
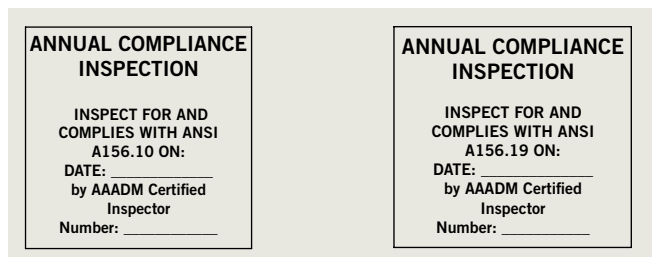

Fig. 4.1.2 Annual compliance inspection labels



# 5 Daily safety check procedure

## 5.1 Power operated swing doors (ANSI/BHMA A156.10)

### NOTICE

All figures and diagrams are for purposes of illustration only and are from AAADM automatic swinging door manual, reprinted with permission.

### 5.1.1 Performing daily safety checks

Perform safety checks daily on your automatic swinging door to insure your customer and employee safety. The daily safety checks are listed in Chapter 4, Safety Information labels.



### TIPS AND RECOMMENDATIONS

Perform these checks while traffic is restricted from all detection and sensing zones.

### 5.1.2 Sensor activation, presence detection safety

1. Check activation sensor by walking toward door opening at moderate speed, door should:
  - Start opening when you are about four feet from door.
  - Open smoothly.
  - Stop at fully open without impact.
2. Move slowly through door opening (approximately six inches/second) stop in door swing path, and pause for ten seconds.
  - Door should remain open.
3. If two way traffic, repeat from other side of door.
4. Step out of sensor zone activating area.
  - After a brief delay (minimum 1.5 seconds) door should close smoothly and without impact.
5. For one way traffic, approach safety side of door and have someone else approach activating side.
  - Door equipped with overhead mounted presence sensor (Fig 5.1.1), as long as you are in safety area of door it should not open.
  - Door equipped with door mounted presence sensors (Fig 5.1.2), door may start to open but should reverse, stop or slow down.
6. Stand motionless in door for at least 4 seconds.
  - Door equipped with overhead mounted presence sensor (Fig 5.1.1), door should not close.
  - Door equipped with door mounted presence sensors (Fig 5.1.2), door may start to close but should reverse, stop or slow down.

Fig. 5.1.1 One way traffic, overhead mounted presence sensor

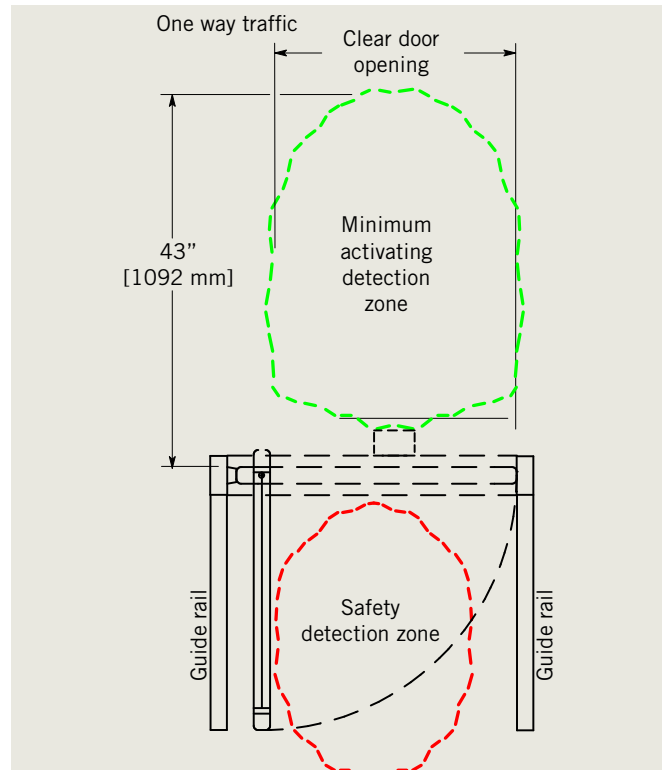

Fig. 5.1.2 One way traffic, door mounted presence sensors





Fine cover

**5.1.3 Double egress knowing act switch activation**

1. Double egress doors are commonly activated by knowing act switch(es).
2. Operate knowing act device, doors should:
  - Open smoothly and stop at fully open without impact.
  - Remain open for a minimum of five seconds before closing.
3. As door closes, approach door from approach side:
  - Door should reopen.
4. Continue across threshold and stand motionless for 10 seconds:
  - Door should not contact you.
5. Continue through door, the door should:
  - Start closing after a minimum of five seconds.
  - Close smoothly and without impact.
6. Approach safety zone side of door:
  - If door equipped with overhead presence sensor (Fig. 5.1.3) door should not open as long as you are in safety zone when door closed.
  - If door equipped with door mounted presence sensor (Fig. 5.1.4) door may start to open but should reverse, stop or slow down.

Fig. 5.1.3 Double egress, overhead presence sensors

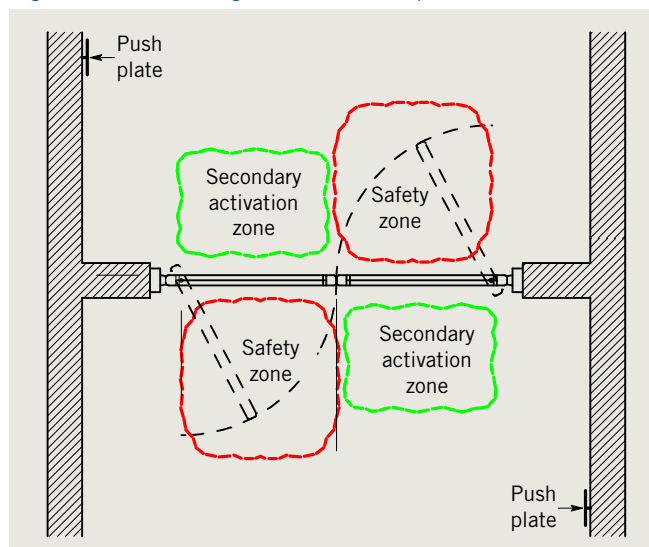
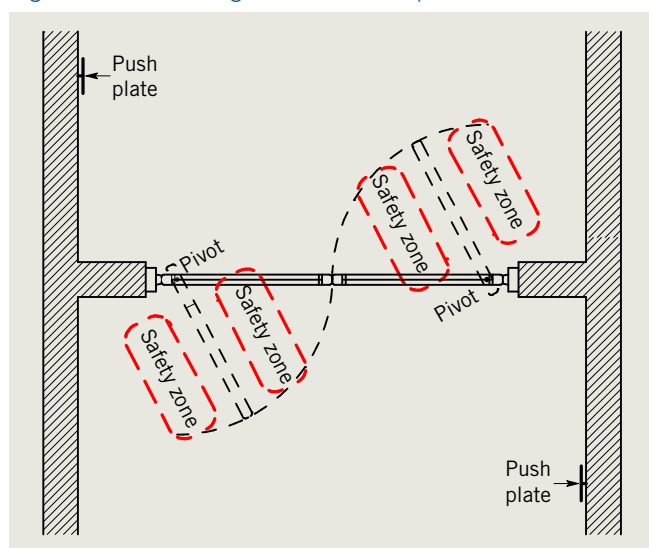

Fig. 5.1.4 Double egress, overhead presence sensors



**5.2 Low energy power operated swing doors (ANSI/BHMA A156.19)**

**5.2.1 Performing daily safety checks**

Perform safety checks daily on your low energy swing door to insure your customer and employee safety. These daily safety checks are also listed in Chapter 4, Safety Information labels, low energy swinging doors.

1. Activate the door by a knowing act (Para.3.4).
  - Door should open at a slow smooth pace (4 seconds or more) and stop without impact.
2. Door must remain fully open for a minimum of 5 seconds before beginning to close.
  - Door should close at a slow smooth pace (4 seconds or more) and stop without impact.
3. Inspect the floor area, it should be kept clean with no loose parts that might cause user to trip or fall. Keep traffic path clear.

4. Inspect door's overall condition. The appropriate signage (Chapter 7) should be present and all hardware should be in good condition.
5. Have door inspected by a dormakaba USA Inc. AAADM certified technician at least annually.



**WARNING**

If there are any problems, discontinue door operation immediately and secure the door in a safe manner. Call your local dormakaba USA Inc. distributor for repair.

# 6 General safety related items

## 6.1 Power operated swing doors (ANSI/BHMA A156.10)

### 6.1.1 Review safety related items and perform checks periodically as noted.



#### TIPS AND RECOMMENDATIONS

Perform these checks while traffic is restricted from all detection and sensing zones.

1. Housekeeping
  - Check door area for tripping or slipping hazards.
  - Check all doors for damage.
  - Make sure all hardware and overhead covers are properly secured.
  - There should be no bulletin boards, literature racks, merchandise displays, or other attractions in the door area that would interfere with the use of the door or encourage people to stop and stand in the door area.
2. Door closing force
  - Force to prevent the door from closing should not exceed 30 pounds measured with a force gauge.
3. Door safety signage
  - Refer to Chapter 7 for door safety signage requirements.
  - Refer to Chapter 4 for Safety Information labels.
4. Activating switch, knowing act (Para. 3.2)
  - Doors equipped with a manual activating switch shall hold door fully open for a minimum of five seconds before closing.
5. Guide rails (Fig. 6.1.1, 2), if used.
  - Check that guide rails or other barriers or separators are present (two per swing door side) and firmly anchored.
  - Rail lengths should be the width of the open door or greater.
6. Lock stile
  - With door open, grasp lock stile of door and attempt to move horizontally and vertically.
  - There should be no looseness in the door pivots or in connections between door and operator.
7. Breakout stop
  - Center pivoted in swinging doors may be supplied with an emergency breakout stop or switch that will allow the door to open in the direction of emergency egress.
  - When the door is pushed into the breakout mode, check that the door will not activate.

Fig. 6.1.1 Guide rails, jamb and floor mounted

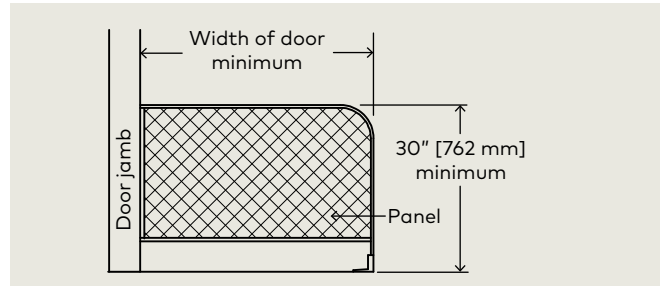
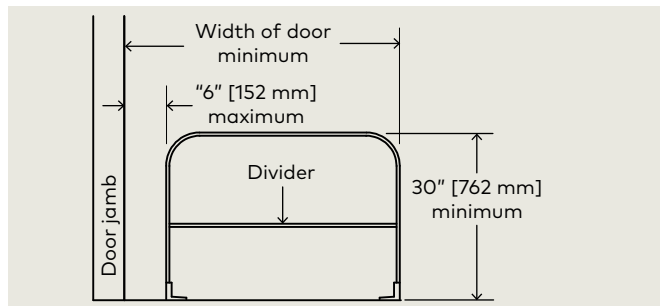

Fig. 6.1.2 Guide rails, free standing, floor mounted



8. Traffic patterns
  - Observe traffic patterns. Plan routing so people enter and exit in a straight approach, directly toward the door opening.
9. Finger guard
  - If installed, inspect finger guard to see that it is secure and in good repair.
10. AAADM safety information label (Chapter 4)
  - An AAADM safety information label should be affixed on the door or door frame in a protected, visible location.
  - If you need additional decals or labels, contact your local authorized dormakaba USA, Inc. distributor.



#### WARNING

If there are any problems, discontinue door operation immediately and secure the door in a safe manner.  
Call your local dormakaba USA, Inc. distributor for repair.

## 6.2 Low energy power operated swing doors (ANSI/BHMA A156.19)

### 6.2.1 Review safety related items and perform checks periodically as noted



#### TIPS AND RECOMMENDATIONS

Perform these checks while traffic is restricted.

1. Housekeeping
  - Check door area for tripping or slipping hazards.
  - Make sure all hardware and overhead covers are properly secured.
  - There should be no bulletin boards, literature racks, merchandise displays, or other attractions in the door area that would interfere with the use of the door or encourage people to stop and stand in the door area.
2. Check all doors for damage.
3. Door closing force
  - Force to prevent the door from closing should not exceed 15 pounds measured with a force gauge.
4. Door safety signage
  - Refer to Chapter 7 for door safety signage requirements.
  - Chapter 4 documents safety information (daily safety check) and annual compliance inspection labels requirements.

5. Lock stile
  - With door open, grasp lock stile of door and attempt to move horizontally and vertically.
  - There should be no looseness in the door pivots or in connections between door and operator.
6. Breakout stop
  - Center pivoted in swinging doors may be supplied with an emergency breakout stop or switch that will allow the door to open in the direction of emergency egress.
  - When the door is pushed into the breakout mode, check that the door will not activate.



#### WARNING

If there are any problems, discontinue door operation immediately and secure the door in a safe manner.  
Call your local dormakaba USA, Inc. distributor for repair.

# 7 ED50/ED100/ED250 door signage

## 7.1 ED100/ED250 operator configured as full energy

### 7.1.1 Overview

Signage and warnings are specified in ANSI /BHMA A156.10, American National Standard for Power Operated Pedestrian Doors, paragraph 11.

### 7.1.2 Door, one way traffic, Fig. 7.1.1.

- Arrow and AUTOMATIC DOOR, one side of decal.
  - Shall be visible from approach side of a swinging door, mounted on door at a height of 50" ± 12" from floor to centerline of sign.
- DO NOT ENTER and AUTOMATIC DOOR, one side of decal (or separate decal for solid doors - DD0739-020).
  - Shall be visible from non-approach side of door that swings towards pedestrians attempting to travel in wrong direction.

### 7.1.3 Door, two way traffic, Fig. 7.1.2.

- Arrow and AUTOMATIC DOOR, one side of decal.
  - Shall be visible from approach side of a swinging door, mounted on door at a height of 50" ± 12" from floor to centerline of sign.
- CAUTION AUTOMATIC DOOR, one side of decal.
  - Swinging doors serving both egress and ingress shall have a "CAUTION AUTOMATIC DOOR" sign visible from swing side of door.
  - Sign shall be mounted on door at a height of 50 ± 12" from floor to centerline of sign.

Fig. 7.1.1 One decal, approach side, non-approach side

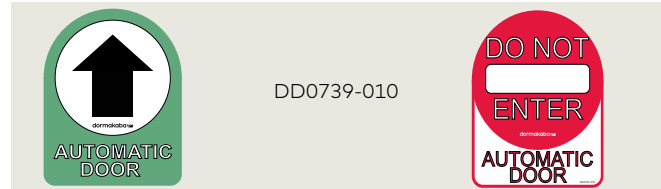

Fig. 7.1.2 One decal, two way traffic

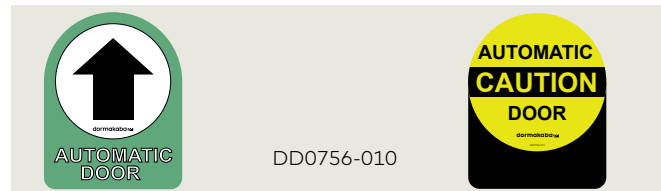
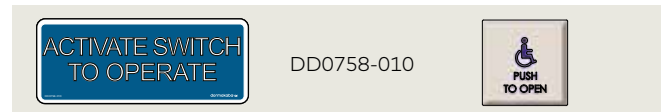

Fig. 7.1.3 ACTIVATE SWITCH TO OPERATE decal



### 7.1.4 Knowing act door.

- ACTIVATE SWITCH TO OPERATE decal.
  - Knowing act doors shall have signage stating "ACTIVATE SWITCH TO OPERATE" on side of door having knowing act switch or other knowing act device.

## 7.2 ED50 operator and ED100/ED250 operator configured as low energy

### 7.2.1 Overview

Signage and warnings are specified in ANSI /BHMA A156.19, American National Standard for Power Assist and Low Energy Power Operated Doors.

### 7.2.2 All low energy doors.

- AUTOMATIC CAUTION DOOR decal.
  - All low energy doors shall be marked with signage visible from both side of door with the words "AUTOMATIC CAUTION DOOR".
  - Signs shall be mounted 50" ± 12" from floor to centerline of sign.

### 7.2.3 Knowing act switch used to initiate door operation.

- ACTIVATE SWITCH TO OPERATE decal.
  - When a knowing act device is used to initiate operation of door operator, door shall be provided with sign on each side of door where switch is operated with message "ACTIVATE SWITCH TO OPERATE".

### 7.2.4 Push/Pull used to initiate door operation.

- PUSH TO OPERATE, PULL TO OPERATE decals.
  - When push/pull is used to initiate operation of door operator, doors shall be provided with the message "PUSH TO OPERATE" on push side of door and "PULL TO OPERATE" on pull side of door.

Fig. 7.2.1 AUTOMATIC CAUTION DOOR decal

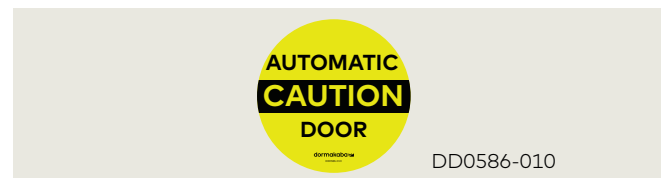
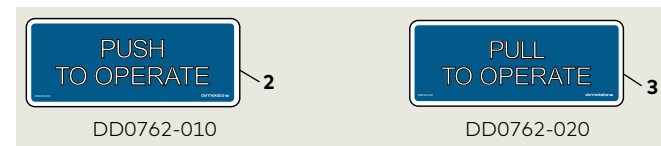

Fig. 7.2.2 ACTIVATE SWITCH TO OPERATE decal



- 1 Activate Switch to Operate DD0758-010

Fig. 7.2.3 PUSH TO OPERATE, PULL TO OPERATE decals



- 2 Push to Operate DD0762-010
- 3 Pull to Operate DD0762-020

### 7.3 Door signage, full energy single swing door

Fig. 7.3.1 One way traffic

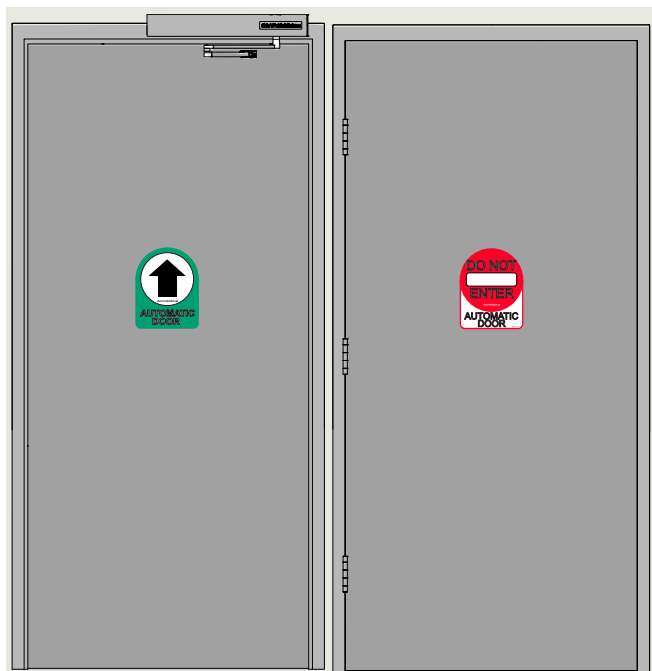
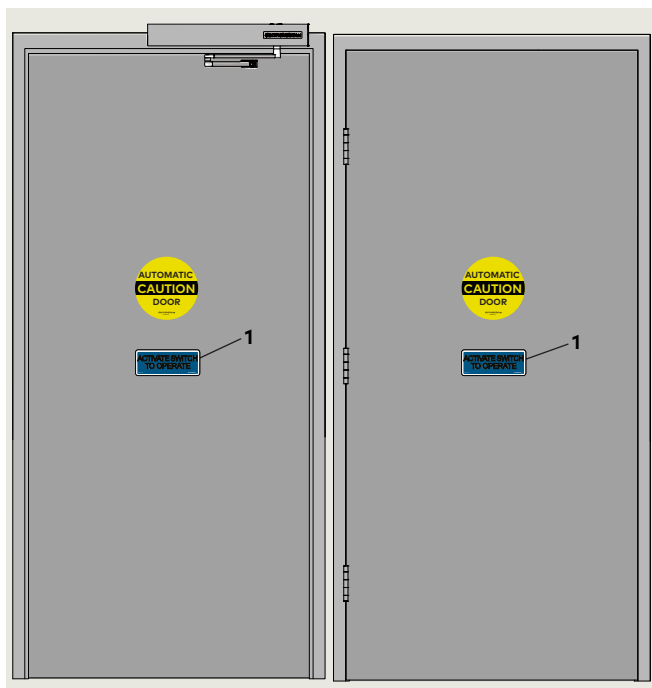

Fig. 7.3.2 Two way traffic



### 7.4 Door signage, low energy swing door

Fig. 7.4.1 Knowing act device initiation of door operation



**1** Activate Switch to Operate DD0758-010

Fig. 7.4.2 Push / Pull initiation of door operation  
 Push to Operate      Pull to Operate

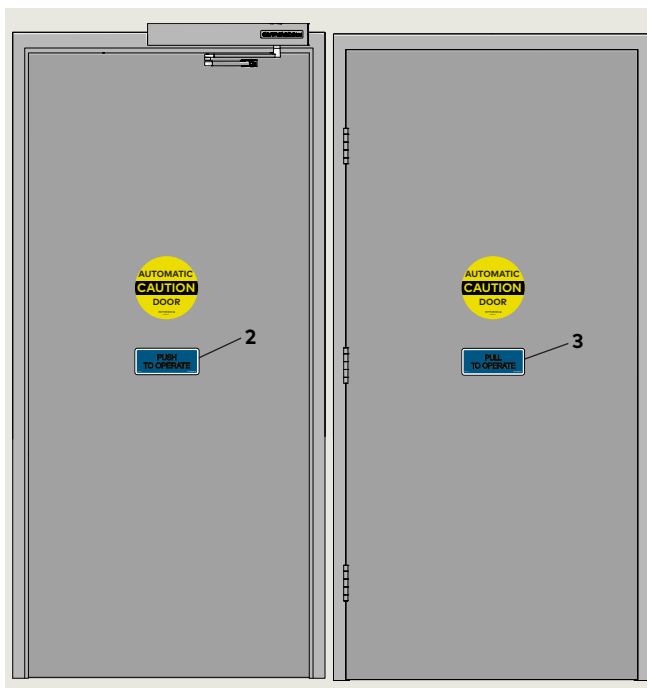

**2** Push to Operate DD0762-010

**3** Pull to Operate DD0762-020

## 7.5 Door signage, full energy double door

Fig. 7.5.1 One way traffic, approach side

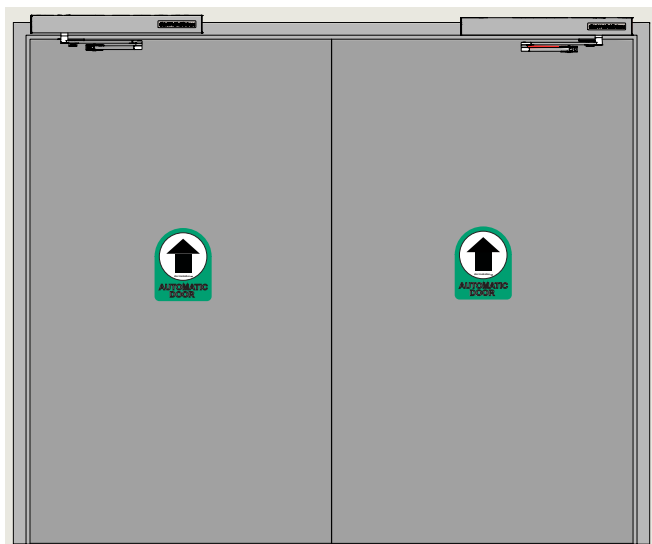

Fig. 7.5.4 One way traffic, non-approach side

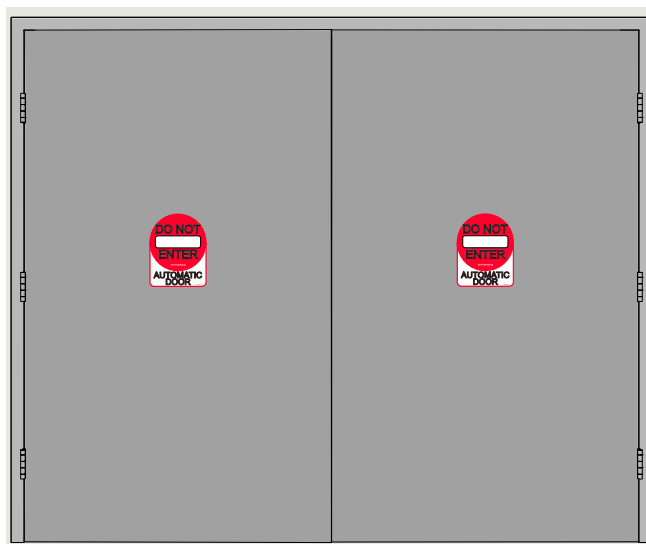

Fig. 7.5.2 Two way traffic, non-swing side

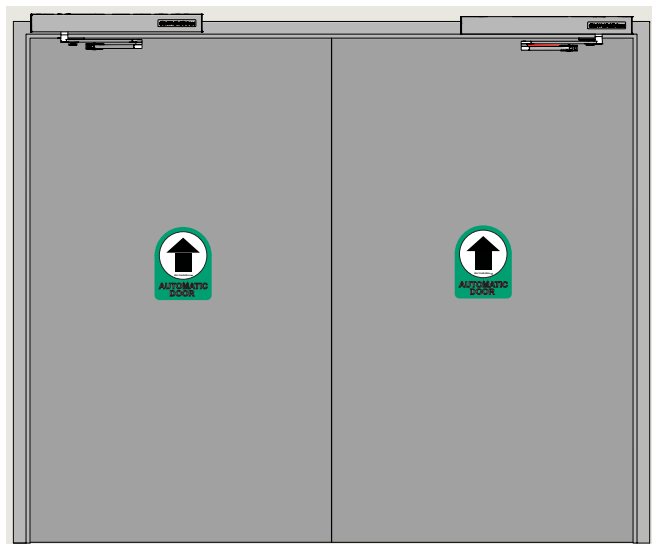

Fig. 7.5.5 Two way traffic, swing side

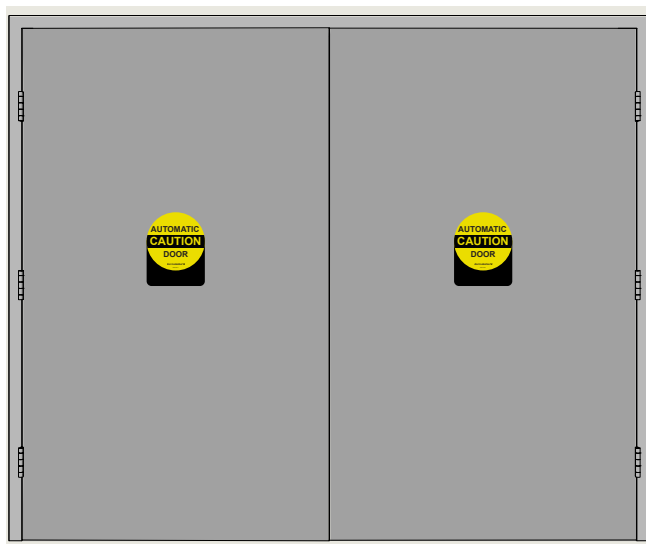

Fig. 7.5.3 One way traffic, approach side, knowing act

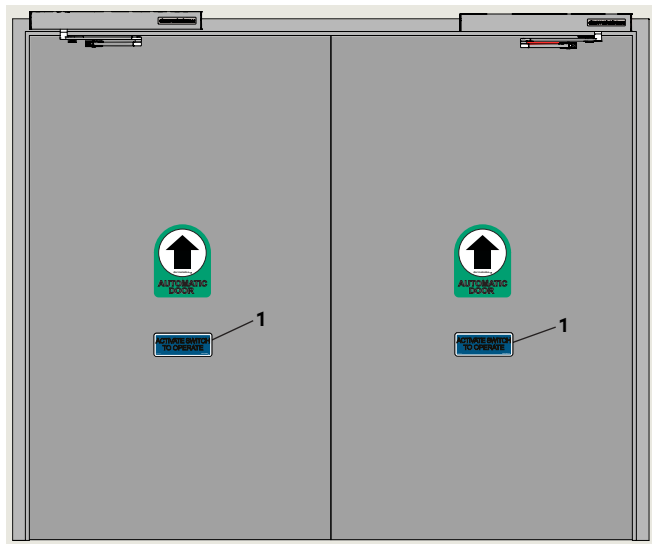
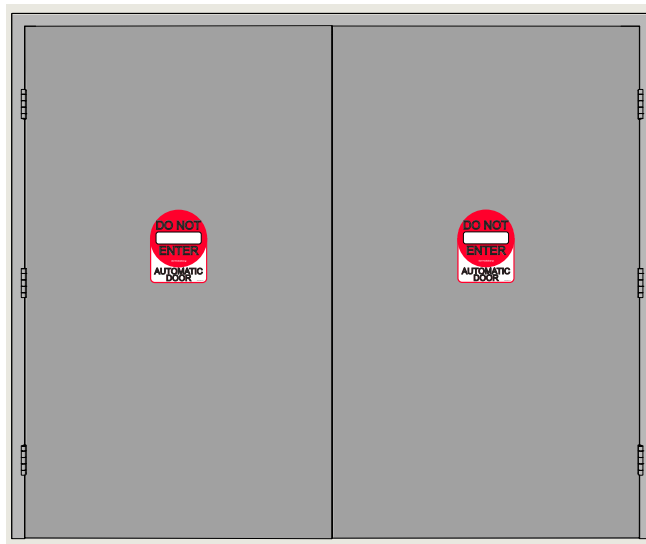

Fig. 7.5.6 One way traffic, non-approach side



1 Activate Switch to  
Operate DD0758-010

## 7.6 Door signage, full energy double egress door

Fig. 7.6.1 One way traffic, interior

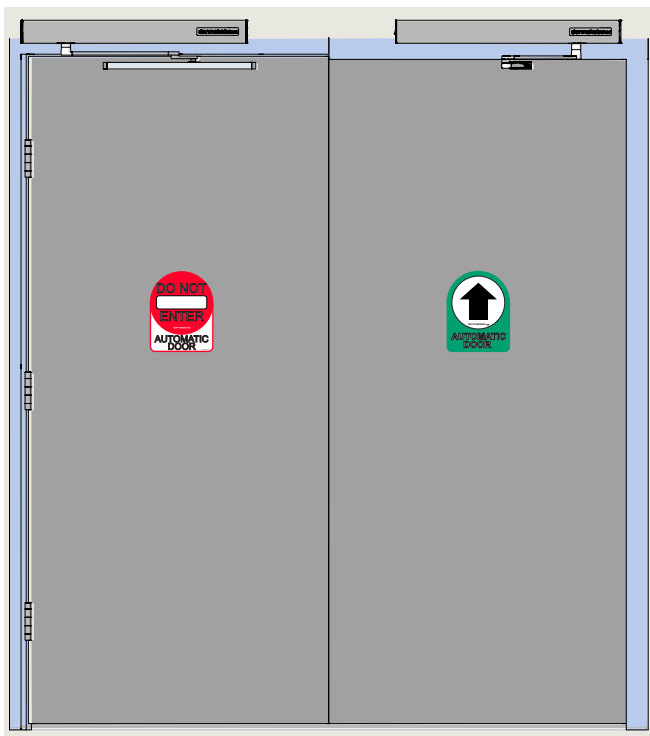

Fig. 7.6.3 One way traffic, exterior

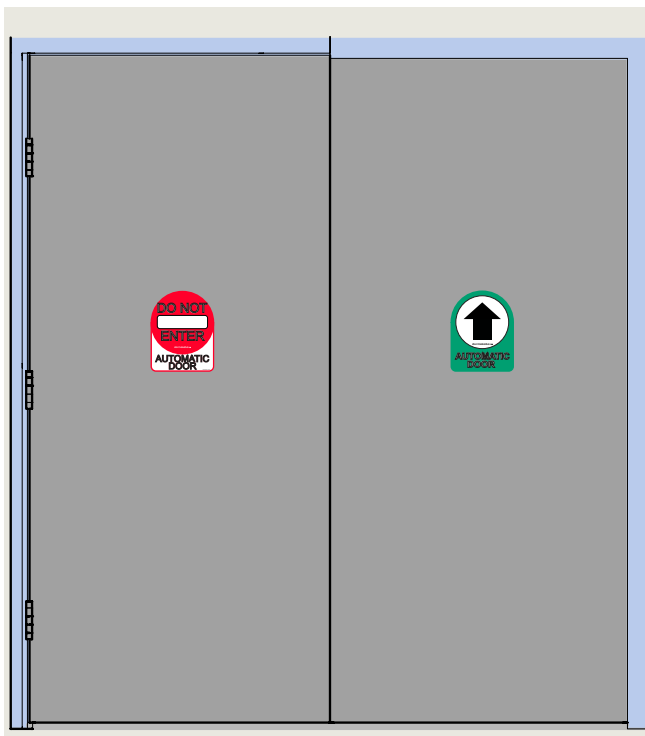

Fig. 7.6.2 Two way traffic, interior

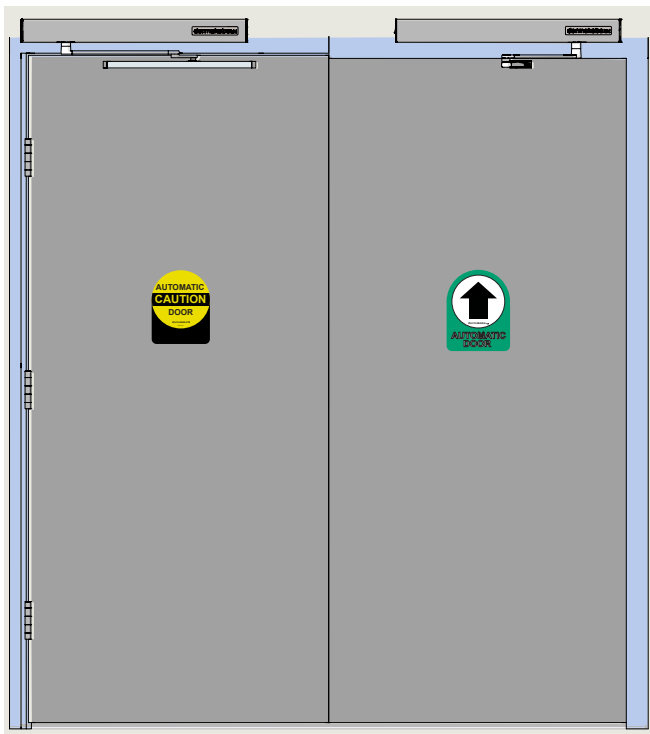
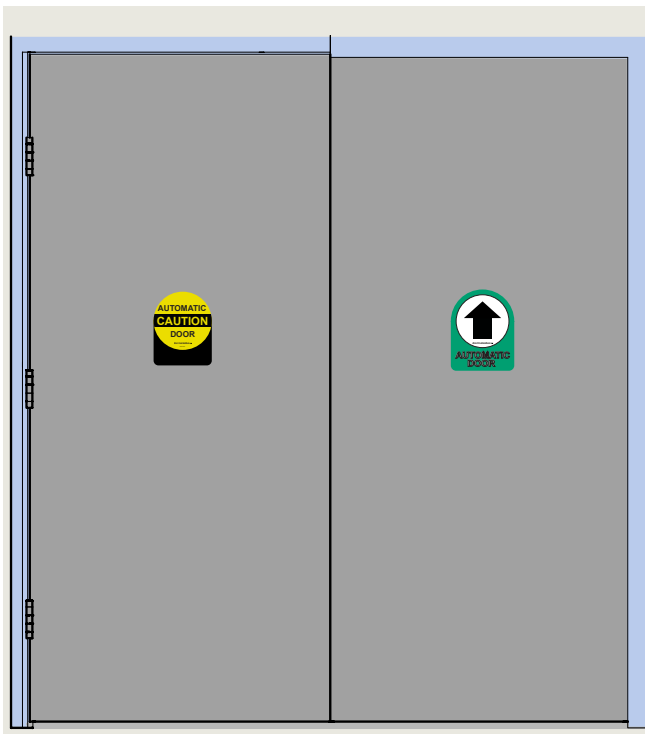

Fig. 7.6.4 Two way traffic, exterior



## 7.7 Door signage, low energy double doors

Fig. 7.7.1 Knowing act, non-hinge side

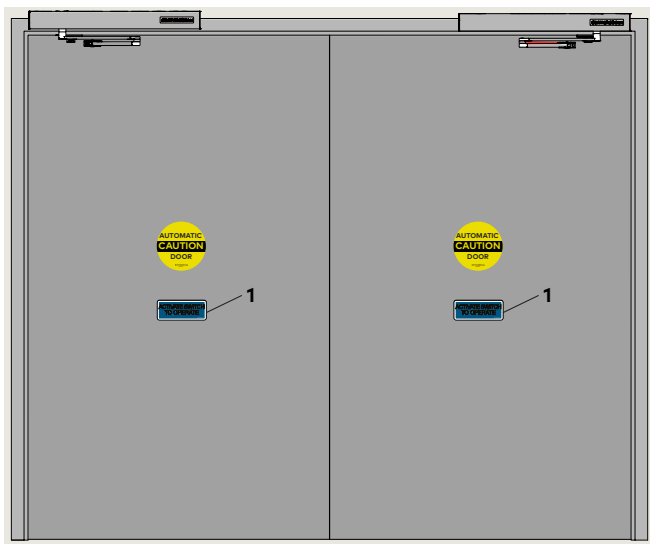

Fig. 7.7.4 Knowing act, non-hinge side

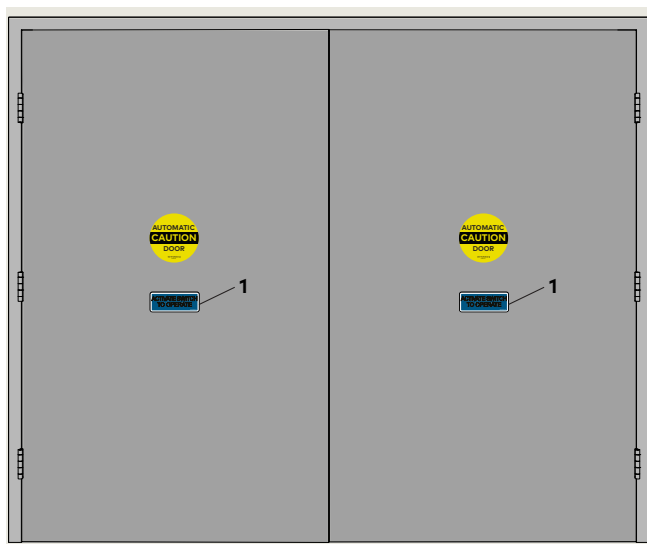

Fig. 7.7.2 Push / Pull, push to operate

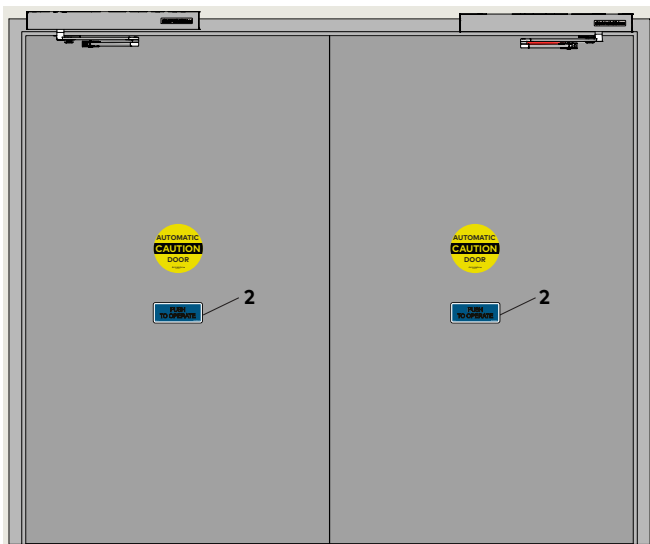

Fig. 7.7.5 Push / Pull, pull to operate

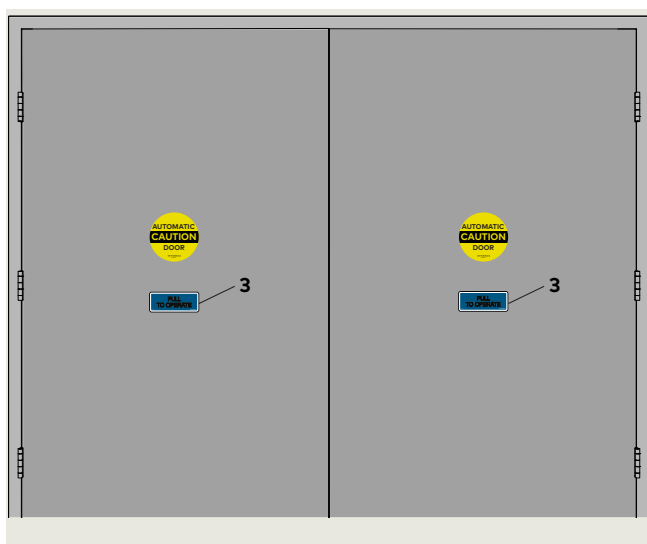

Fig. 7.7.3 Double egress, knowing act

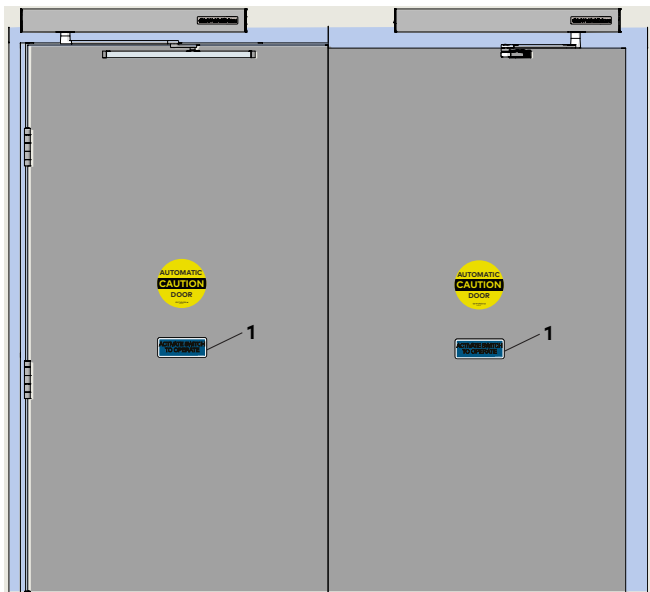
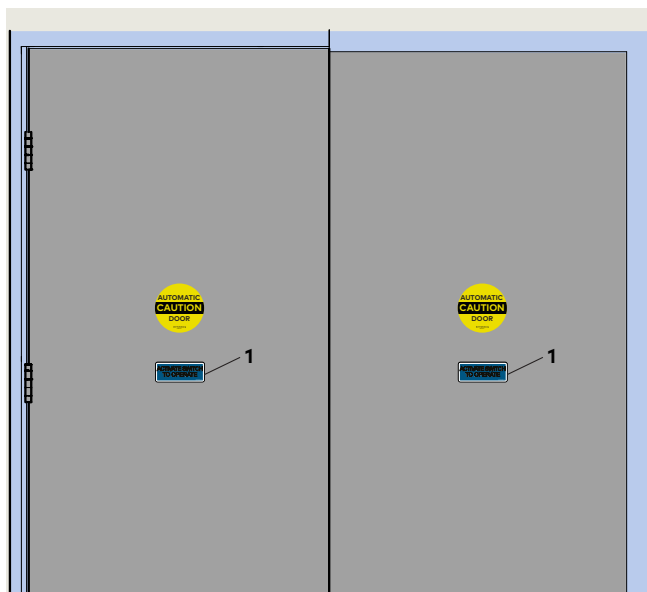

Fig. 7.7.6 Double egress, knowing act





# 8 ED50/ED100/ED250 maintenance

## 8.1 ED50/ED100/ED250 environment and maintenance

Fig. 8.1.1 Right hand push door–  
ED50/ED100/ED250 with fine cover

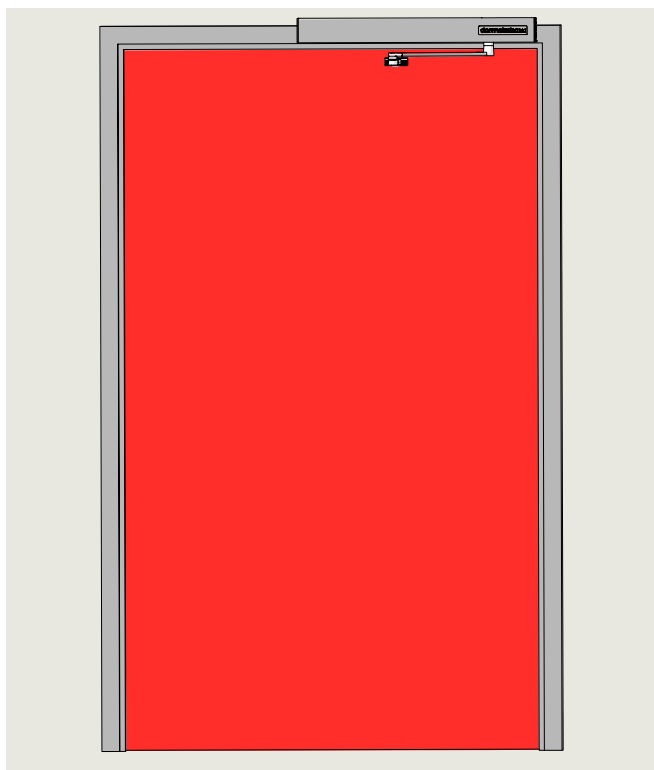

### 8.1.1 Areas around door(s) and door swing radius.

Areas around doors and door swing radius must be kept clear of all obstacles.

### 8.1.2 Cleaning



#### WARNING

Cleaning of fine cover surfaces must be done with Mode switch (Para. 3.6) in Close position!

External surfaces of fine cover can be cleaned with a damp cloth and commercial cleaning agents.



#### TIPS AND RECOMMENDATIONS

Abrasive (scouring) agents should not be used as they may damage external surfaces.

### 8.1.3 Water and other liquids.

#### CAUTION

No water or other liquids must be sprayed or spilled on ED50/ED100/ED250 fine cover!

## 8.2 ED operator status LEDs

Fig. 8.2.1 Operator status LEDs

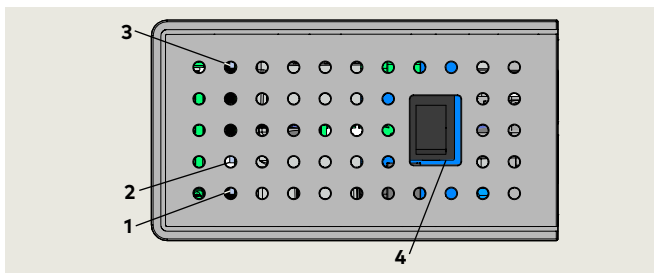

- 1 Red LED
- 2 Yellow LED
- 3 Green LED
- 4 Power switch

### 8.2.1 Operator status LEDs.

1. Red LED  
Blinking codes are used to indicate system status, operating conditions or certain error codes.
2. Yellow LED  
Maintenance interval indicator. When illuminated, an indication the operator system should be serviced.
3. Green LED
  - On, internal 24 Vdc power is On.
  - Off, internal 24 Vdc power is Off.



#### WARNING

If there are any problems, discontinue door operation immediately and secure the door in a safe manner.  
Call your local dormakaba USA Inc. distributor for repair.

